



Riva2 500

Inset Convector Fire - Balanced Flue
with Thermostatic Remote Control



Installation & User Instructions

IMPORTANT

THE OUTER CASING, FRONT AND GLASS PANEL BECOME EXTREMELY HOT DURING OPERATION AND WILL RESULT IN SERIOUS INJURY AND BURNS IF TOUCHED. IT IS THEREFORE RECOMMENDED THAT A FIREGUARD COMPLYING WITH BS 8423 (LATEST EDITION) IS USED IN THE PRESENCE OF YOUNG CHILDREN, THE ELDERLY OR INFIRM.

This product contains a Heat resistant glass panel. This panel should be checked during Installation and at each servicing interval. If any damage is observed on the front face of the glass panel (scratches, scores, cracks or other surface defects), the glass panel must be replaced and the appliance must not be used until a replacement is installed. Under no circumstances should the appliance be used if any damage is observed, the glass panel is removed or broken.

It is essential that ALL of the screws that retain the glass frame are replaced and tightened correctly. Under no circumstances should the appliance be operated if any of these screws are loose or missing.

These Instructions must be left with the appliance for future reference and for consultation when servicing the appliance. Please make the customer aware of the correct operation of the appliance before leaving these instructions with them.

The commissioning sheet found on Page 3 of this Instruction manual must be completed by the Installer prior to leaving the premises.

CONTENTS

RIVA2 500 - BALANCED FLUE

Covering the following models:

MODEL	Riva2 500
Nat Gas	134-249
LPG	134-401

Appliance Commissioning Checklist	3
User Instructions	4
Installation Instructions	13
Technical Specifications	13
Site Requirements	15
Installation	19
Commissioning	37
Servicing Requirements	38
Fault Finding	38
How to replace parts	41
Spare parts list	48
Service Records	50
Information Requirement - Gas Heaters	51

WARNING



In the event of a gas escape or if you can smell gas, please take the following steps:

- Immediately turn off the gas supply at the meter/emergency control valve
- Extinguish all sources of ignition
- Do not smoke
- Do not operate any electrical light or power switches (On or Off)
- Ventilate the building(s) by opening doors and windows
- Ensure access to the premises can be made

Please report the incident immediately to the National Gas Emergency Service Call Centre on 0800 111 999 (England, Scotland and Wales) , 0800 002 001 (N. Ireland) or in the case of LPG, the gas supplier whose details can be found on the bulk storage vessel or cylinder.

The gas supply must not be used until remedial action has been taken to correct the defect and the installation has been recommissioned by a competent person.



It is a requirement of the Building Regulations 2010 that the installation of this appliance is notified to the Local Authority. It is the responsibility of the GasSafe registered installer to carry out this notification to the Local Authority via the GasSafe register Competent Persons Scheme in England and Wales (different rules apply in Scotland and Northern Ireland).

When the installation has been notified, GasSafe will send a Building Regulations Compliance Certificate to you containing details of the work completed. Please ensure that the person responsible for the installation of this appliance completes this notification and records it in the Appliance Commissioning Checklist on page 3.

IT IS YOUR RESPONSIBILITY TO COMPLY WITH THE BUILDING REGULATIONS AND BE ABLE TO PRODUCE THIS CERTIFICATE SHOULD IT BE REQUIRED IN THE FUTURE.

APPLIANCE COMMISSIONING CHECKLIST

To assist us in any guarantee claim please complete the following information:-

IMPORTANT NOTICE

Explain the operation of the appliance to the end user, hand the completed instructions to them for safe keeping, as the information will be required when making any guaranteed claims.

FLUE CHECK	PASS	FAIL
1. Flue Is correct for appliance		
2. Flue flow Test N/A		
3. Spillage Test N/A		
GAS CHECK		
1. Gas soundness & let by test		
2. Standing gas pressure	mb	
3. Appliance working pressure (on High Setting) Minimum Pressure Requirement: NG - 17.5mbar LPG - 34.5mbar NB All other gas appliances must be operating on full	mb	
4. Gas rate	m ³ /h	
5. Does Ventilation meet appliance requirements N/A		
SAFETY CHECK		
1. Check soundness of the Thermocouple connections - including tightness and lead integrity		
2. Glass checked to ensure no damage, scratches, scores or cracks		
3. Glass frame secured correctly and all screws replaced		
BUILDING CONTROL NOTIFICATION		
	YES	NO
1. Installer notified GasSafe/Local Authority of installation via Competent Persons Scheme?		

RETAILER AND INSTALLER INFORMATION

Retailer	Installation Company
.....
.....
Contact No.	Engineer
Date of Purchase	Contact No.
Model No.	GasSafe Reg No.
Serial No.	Date of Installation
Gas Type	

GENERAL

BALANCED FLUE

Installation and servicing must only be carried out by a competent person whose name appears on the GasSafe register. To ensure the engineer is registered with GasSafe they should possess an ID Card carrying the following logo:



In all correspondence, please quote the appliance type and serial number, which can be found on the data badge located on a plate attached to the lower slotted trim or on the Commissioning Checklist on Page 3.

Do not place curtains above the appliance: You must have 300mm clearance between the appliance and any curtains at either side.

No furnishings or other objects should be placed within 1 metre of the front of the appliance.

If a shelf is fitted, a distance of 150mm (studwork installation) or 300mm (masonry installation) above the appliance is required.

If any cracks appear in the glass panel do not use the appliance until the panel has been replaced.

If, for any reason, the flue has to be removed from the appliance, the seals must be replaced in the inner spigot.

Do not obstruct the flue terminal in any way, i.e. by planting flowers, trees, shrubs etc. in the near vicinity, or by leaning objects against the terminal guard.

Do not put any objects on the terminal guard; it will lose its shape.

If you use a garden sprinkler, do not let quantities of water into the flue terminal.

This product is guaranteed for 5 years from the date of installation, as set out in the terms and conditions of sale between Gazco and your local Gazco retailer. Please consult with your local Gazco retailer if you have any questions. In all correspondence always quote the Model Number and Serial Number.



IMPORTANT: NEVER position a television or screen above this appliance.

OPERATING THE APPLIANCE

The appliance is operated by thermostatic remote control.

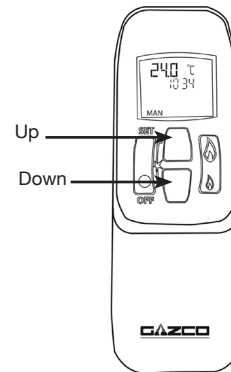

Turning the appliance On

Your remote can control the gas appliance from pilot ignition through to shut down.

To turn the appliance on press the OFF button and the UP button simultaneously. You hear several short signals.

The pilot and main burner ignite and the remote is now in Manual Mode:



IMPORTANT: YELLOW FLAMES TYPICALLY APPEAR WHEN THE APPLIANCE HAS REACHED NORMAL OPERATING TEMPERATURE. THIS CAN TAKE UP TO 30 MINUTES.



WARNING: IF THE APPLIANCE FAILS TO LIGHT OR BECOMES EXTINGUISHED IN USE, WAIT 3 MINUTES BEFORE ATTEMPTING TO RELIGHT.

There are 3 different modes available for controlling and operating the appliance:

1. Manual Mode
2. Temp Mode (Automatic)
3. Timer Mode (Automatic)

In **MANUAL MODE** you can:

- turn on the main burner using the UP button
- regulate the flame from high to low and back
- turn off the burner leaving just the pilot burning

In **TEMP MODE (Automatic)** you can:

- set the room temperature so the thermostat in the remote automatically maintains that temperature

In **TIMER MODE (Automatic)** the appliance:

- turns on and off according to the set time periods
- automatically regulates the room temperature during the set periods



NOTE: When operating the appliance in Temp or Timer mode, the pilot remains lit and the appliance then automatically switches on at programmed times to bring the room to the set temperature whether or not you are in the room.

NEVER LEAVE ANY COMBUSTIBLE MATERIALS WITHIN 1 METRE OF THE FRONT OF THE APPLIANCE.

SWITCHING BETWEEN MODES

Press the SET button to change to Temperature Mode. Press again to change to Timer Mode.

Keep pressing to run through all operating modes. These are:

- MAN
- DAY TEMP
- NIGHT TEMP
- TIMER

and back to MAN

NOTE: MAN mode can also be reached by pressing either the UP or DOWN button.

MANUAL MODE

Press the OFF button and the UP button simultaneously. You hear several clicks and audible beeps as the appliance begins the ignition process, (up to 30 seconds).

Turning the appliance Off:

Press the OFF button to turn the appliance off.

FOR SAFETY, YOU MUST WAIT 30 SECONDS BEFORE LIGHTING THE APPLIANCE AGAIN.

Increasing the Flame Height:

Press the UP button once to increase flame height one stage. Press and hold the UP button to increase to maximum.

Decreasing the Flame Height:

Press the DOWN button once to decrease flame height one stage. Press and hold the DOWN button to decrease to minimum. At the lowest point the appliance goes to 'Standby Mode' (Only Pilot lit).



NOTE: While pressing a button a symbol indicating transmission appears on the display. The receiver confirms transmission with a sound signal.

TEMP MODE (AUTOMATIC)

The display shows the current **room** temperature.

To increase or decrease the appliance's output:

Press the SET button to select either the DAY TEMP or the NIGHT TEMP mode by briefly pressing the SET button.

Hold the SET button until the TEMP display flashes and then let go.

Set the desired temperature with the UP and DOWN arrows.

(Minimum temperature 5C, maximum 40C or 40F to 99F when Fahrenheit is the preferred option)

Press the OFF button to stop the display flashing or wait to return to TEMP mode.



NOTE: If you set a temperature that is beneath the current room temperature, the appliance automatically switches to PILOT (Stand by).

If you would like the Night temperature control to turn off then decrease the temperature until [--] is displayed.

TIMER MODE (AUTOMATIC)

There are two programmable settings you can make over a 24 hour period, P1 and P2. These are normally used to provide an early morning and evening setting for each working week:

- P1 + ● = Start Timed Setting 1
- P1 + > = End of Timed Setting 1
- P2 + ● = Start Timed Setting 2
- P2 + > = End of Timed Setting 2

P1 - Program 1 for a Timed Setting

Press the SET button until the TIMER mode is displayed.

Hold the SET button. The displays flashes the current time for P1. **While the time displayed is flashing you can alter the hours and minutes set.**

To set the time your appliance first lights, change P1 ●

- Press the UP button to alter the hour.
- Press the DOWN button to alter the minutes in 10 minute increments.

Press SET again to move to the end setting for P1 > This is the time your appliance first shuts down:

- Press the UP button to alter the hour.
- Press the DOWN button to alter the minutes.

P2 - Program 2 for a Timed Setting

Use the same steps outlined in 2.8 to change the setting for P2. If you have already set P1 and want to alter the setting for P2 only:

- Press the SET button until TIMER mode is displayed.
- Hold the SET button **until the display flashes the current time** for P1 ●
- Press the SET button once again to scroll past the settings for P1 ● and P1

With the time still flashing:

- Press the UP button to alter the hour
- Press the DOWN button to alter the minutes

Once all four times are set press the OFF button.

To view existing settings:

- Select Timer Mode
- Press and briefly hold the SET button you see the start time for P1.
- Repeat the above step for the start and end of each program.

Low Battery

“BATT” is displayed on the remote when its batteries need replacement.

Setting the time

Simultaneously press the up and down buttons.

Press the up button to set the hour and the down button to set the minutes.

Press OFF to return to the manual mode or simply wait.

Setting the °C/24 Hour or °F/12 Hour clock

Press OFF and the down arrow until the display changes from °C/24 hour clock to °F/12 hour clock and vice versa.

i If the remote is removed, lost or damaged, signals transmitted to the receiver cease. Your appliance will go to standby (pilot) mode after 6 hours.

TROUBLESHOOTING



IMPORTANT: In the unlikely event that the handset fails to communicate correctly with the appliance it may be necessary to turn off the gas supply at the isolation valve until any problems can be resolved.

The gas meter and isolation valve can be located outside in a meter box, under the stairs, beneath the kitchen sink or in the garage. Whilst this list is not exhaustive, it is important to be able to identify the location of the valve in case of any gas emergency.

To turn off the gas supply, simply turn the handle so the lever is at 90 degrees to the upright gas pipe.

If you smell gas, open doors and windows and never operate any electrical switches. Immediately call the Gas Emergency Services on 0800 111 999.

CHANGING APPLIANCE BATTERIES

The appliance batteries are located on a bracket attached to the lower slotted trim.

Make sure the appliance and surrounds are cool before removing the batteries.

Remove the 2 side trims. These are held on by magnets.

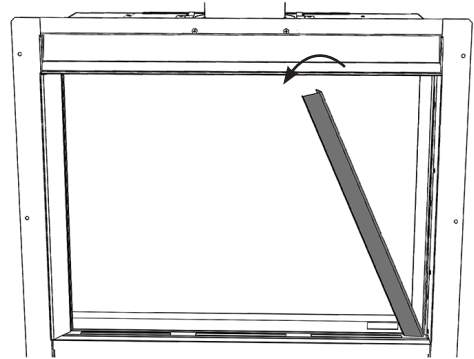

Lift out the bottom slotted trim. Note the orientation of the metal shield for reassembly.

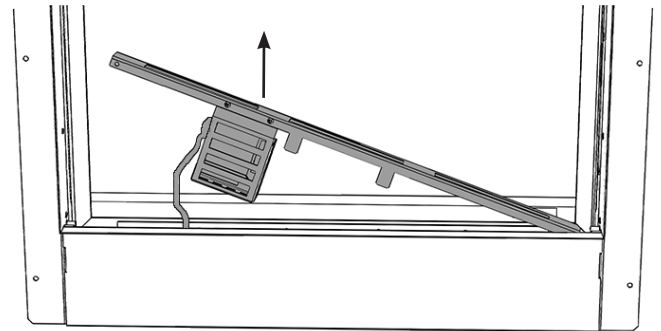

Disconnect the battery lead from the battery pack.

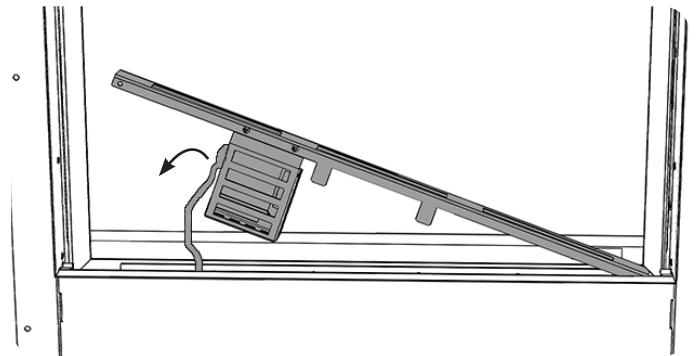

Remove the battery pack from the bracket.

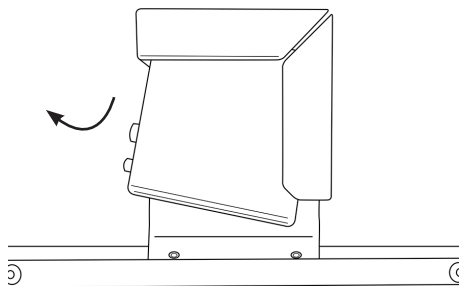

Remove the cover by sliding off in the direction of the arrow as shown.

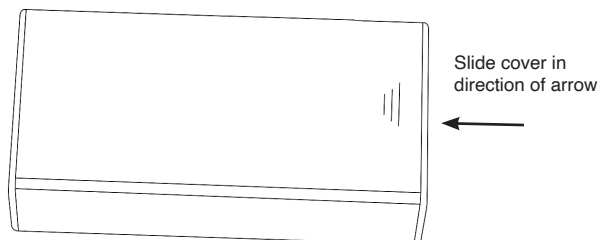

Correctly position the four new AA size batteries into the battery holder.

i It is essential to use high quality batteries (Duracell or equivalent) when replacing batteries in the handset or control box.

Re-assemble in reverse order.

! PLEASE ENSURE NO WIRES ARE TRAPPED BEFORE REPLACING THE LOWER SLOTTED TRIM. THE LEADS ARE EASILY DAMAGED.

CLEANING THE APPLIANCE

Make sure the appliance and surrounds are cool before cleaning.

If a decorative front has been fitted to the appliance, please remove by referring to the separate instructions supplied.

Remove the glass frame by removing the 2 side trims. These are held on by magnets.

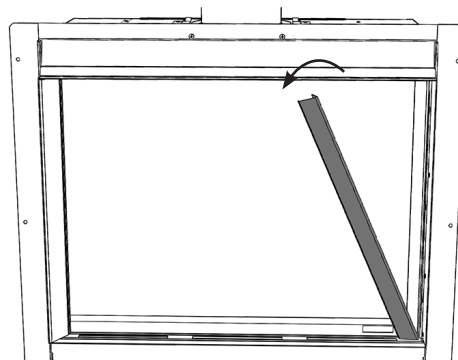

Lift out the bottom slotted trim. Note the orientation of the battery box for reassembly.

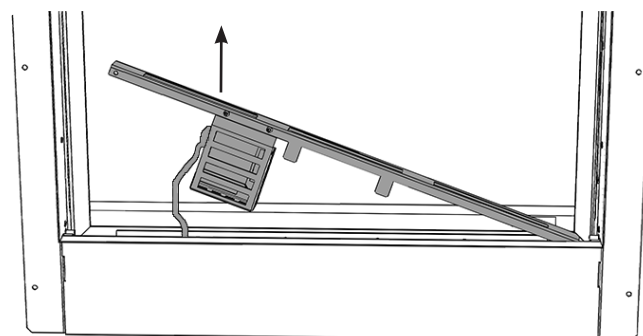

Disconnect the battery lead from the battery pack attached to the lower slotted trim.

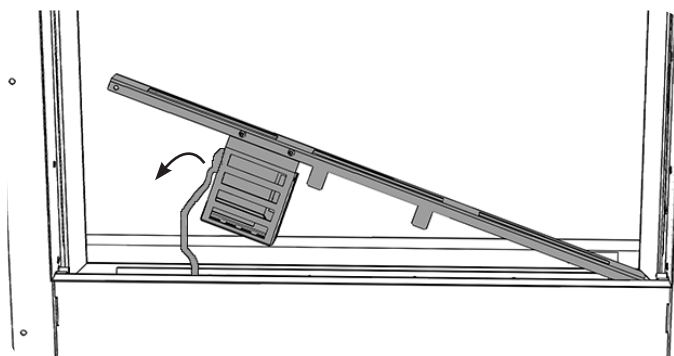

Remove the screws at the base of the glass frame see A.

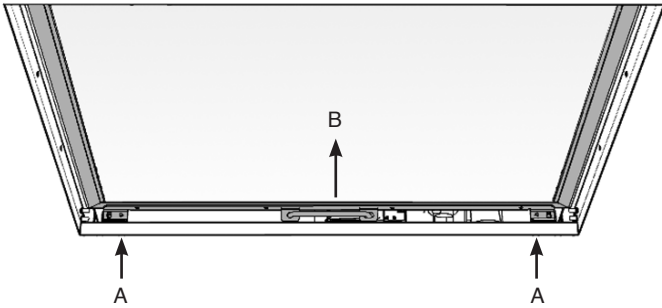

Pull up the handle at the front, see B.

Whilst supporting the top, lift the glass frame using the handle, up and over the lower edge.

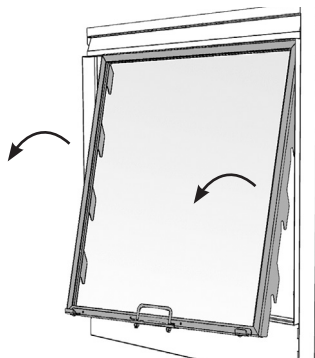

Remove the logs and Embaglow and place on a dry, clean surface.

The logs should not require cleaning. Do not use a vacuum cleaner or brush to clean the logs, any large pieces of debris may be removed by hand.

Ensure any debris is removed from the burner ports.

Use a damp cloth to clean the outer casing of the appliance.

To clean the glass surface use a non abrasive glass cleaner and soft cloth.

The glass frame must be refitted to the appliance following cleaning or servicing.

Ensure that the rope seal on the back of the glass frame is intact.

To replace the glass frame, position so the hooks on the back of the frame fit over the side pins.

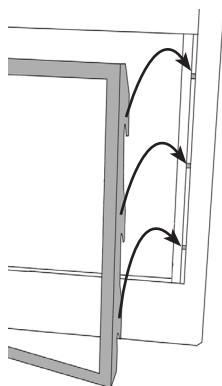

Push the handle down.

Replace the screws. As the screws are tightened the glass frame is pulled down against the hooks and forms a seal.

Replace ALL of the securing screws ensuring that a screw is present in all fixing slots.



UNDER NO CIRCUMSTANCES SHOULD THE APPLIANCE BE USED IF ANY OF THE GLASS FRAME RETAINING SCREWS ARE LOOSE OR MISSING.

Replace the lower trim, ensuring that the battery box is connected and in the correct orientation.



PLEASE ENSURE NO WIRES ARE TRAPPED BEFORE REPLACING THE LOWER SLOTTED TRIM. THE LEADS ARE EASILY DAMAGED.

Replace the 2 magnetic side trims.

NEVER OPERATE THE APPLIANCE WHEN THE GLASS FRAME IS REMOVED OR BROKEN.

Replace the decorative front by referring to the separate instructions supplied with the front.

NOTE: ENSURE THAT THE LOGS ARE POSITIONED CORRECTLY. ONLY USE THE CORRECT AMOUNT OF LOGS AS SPECIFIED IN THE DIAGRAMS.

LOG LAYOUT

LOGS MUST BE POSITIONED ACCORDING TO THE FOLLOWING INSTRUCTIONS TO GIVE THE CORRECT FLAME EFFECT.

Ensure the Burner Tray and Log Burners are clean and free from any debris.
The main components are clearly individually labelled.

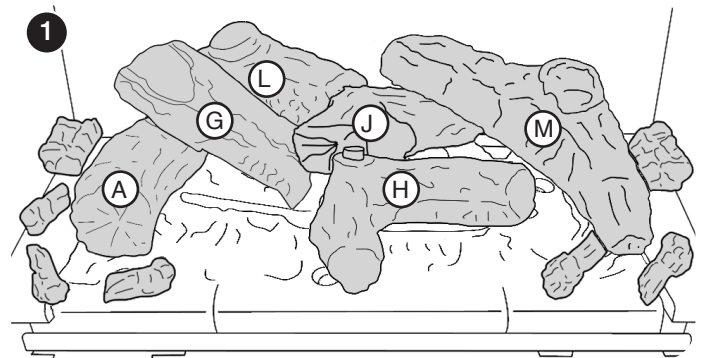

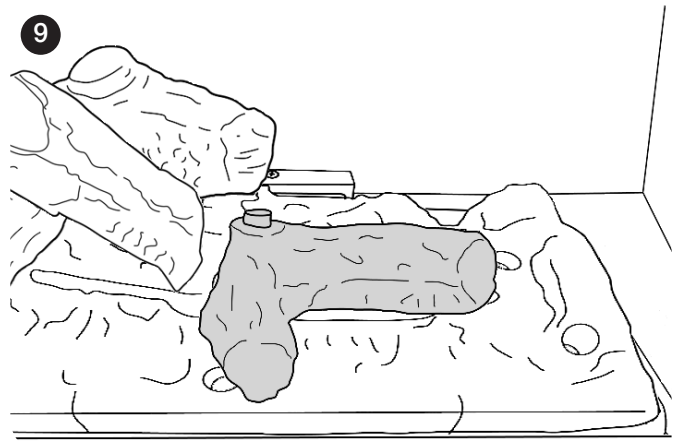
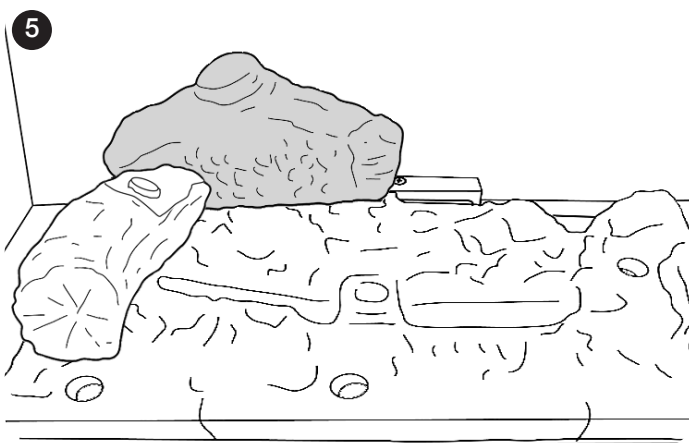
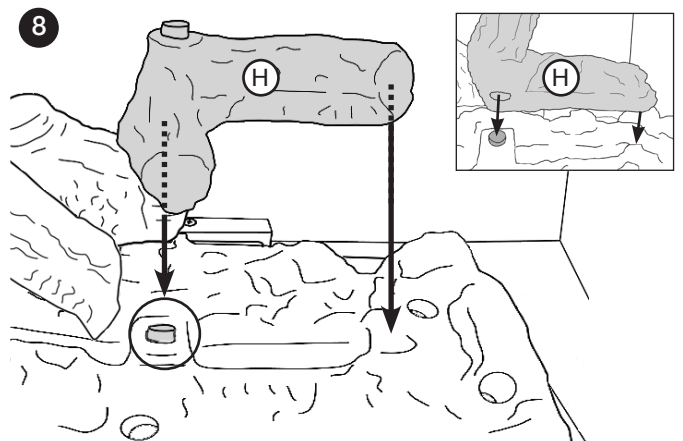
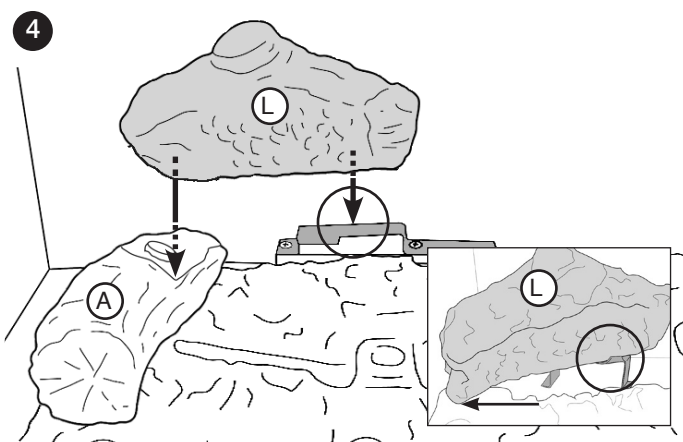
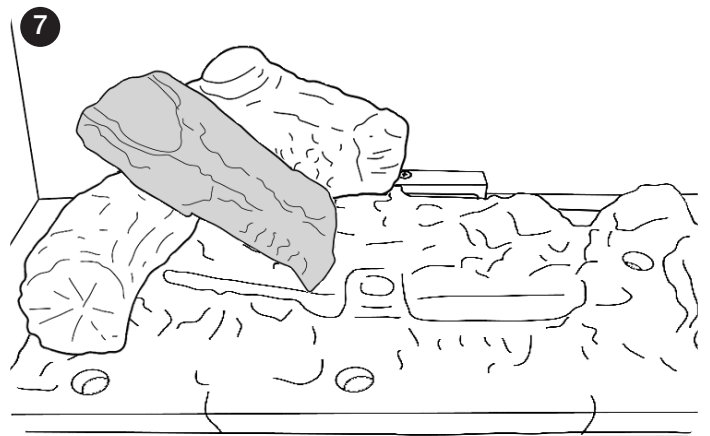
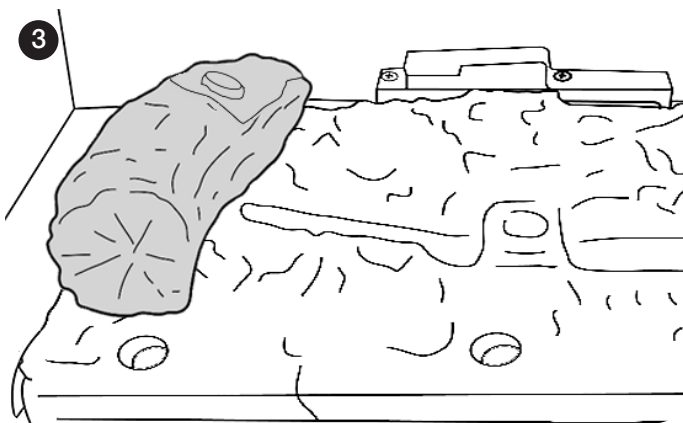
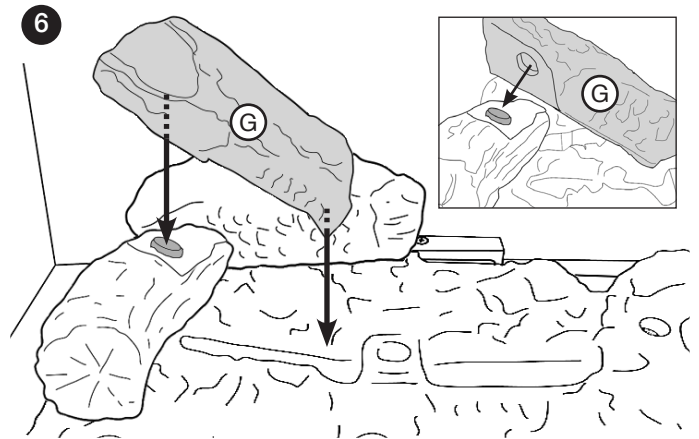
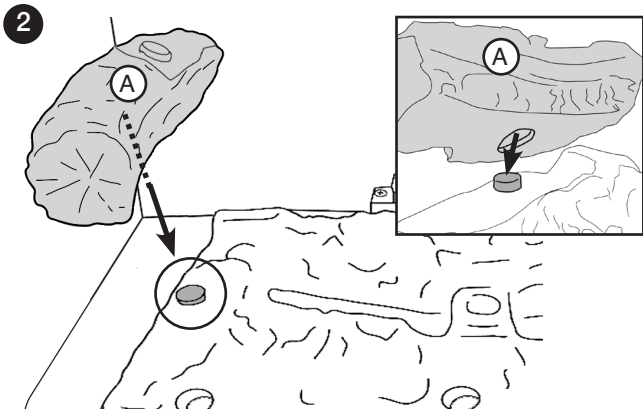

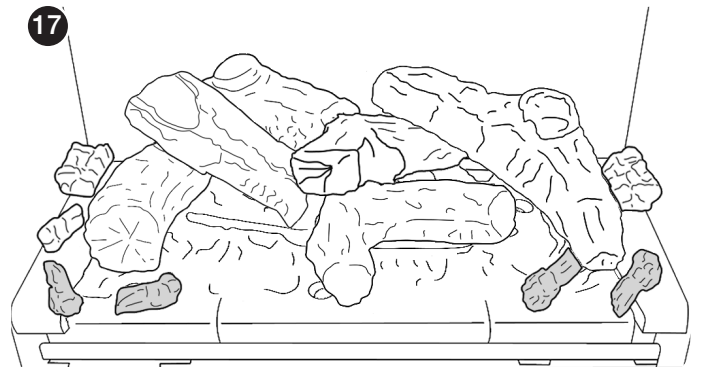
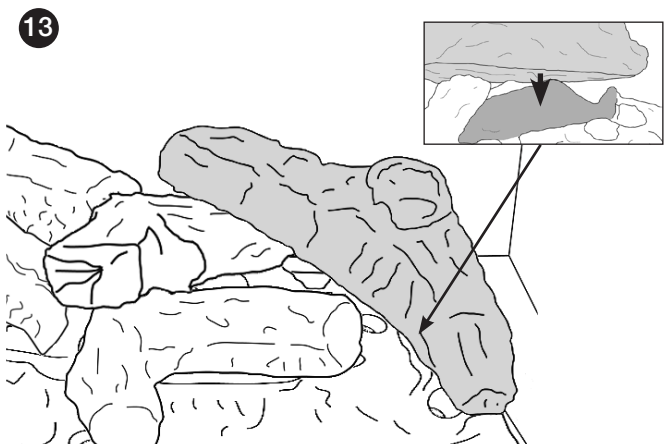
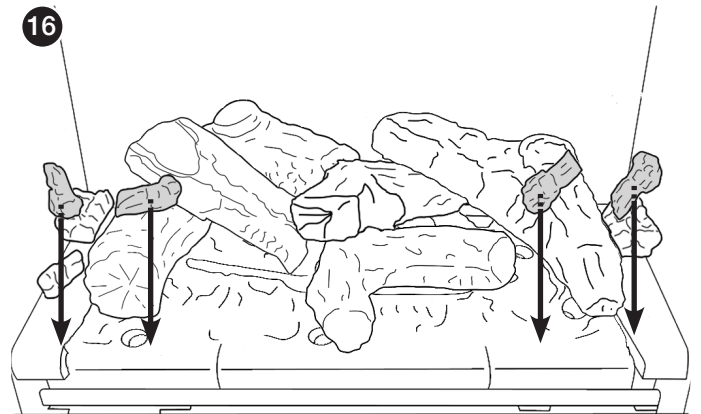
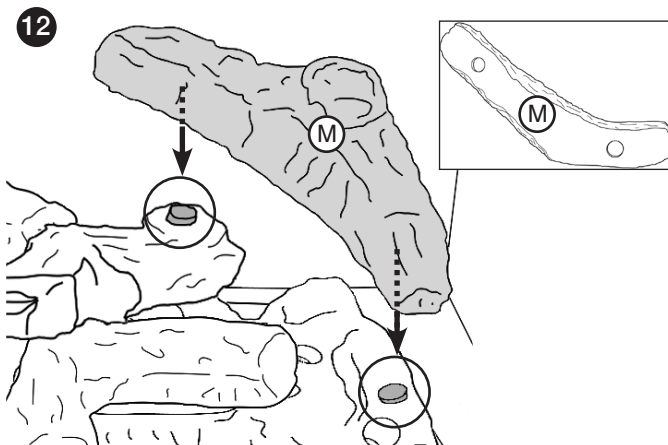
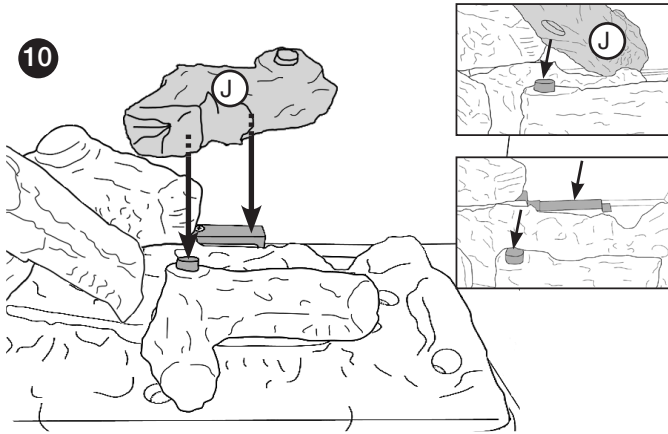

Sparingly lay Embaglow over the small ports in the base of the burner tray. This will create a glowing effect when the appliance is lit.

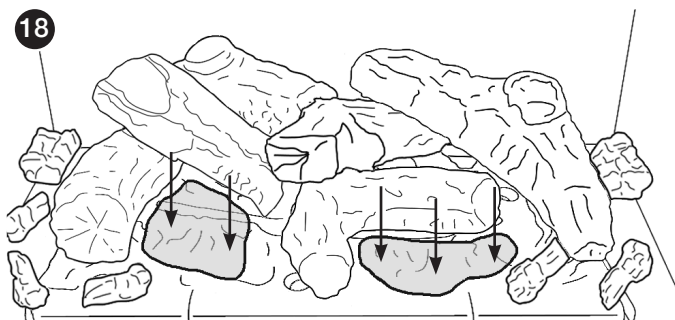

Take care not to use more than half a packet per application.
WARNING - DO NOT PLACE NEAR THE PILOT AREA.

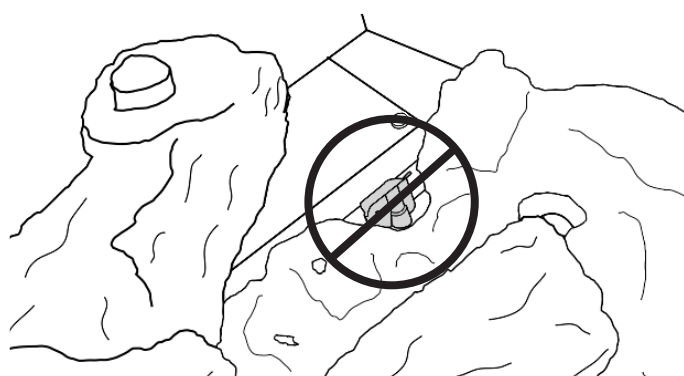

NOTE: ENSURE THAT THE LOGS ARE POSITIONED AS ABOVE. ONLY USE THE CORRECT AMOUNT OF LOGS AS SPECIFIED IN THE DIAGRAMS.

FLAME FAILURE DEVICE

This is a safety feature incorporated on this appliance which automatically switches off the gas supply if the pilot goes out and fails to heat the thermocouple.

IF THIS OCCURS DO NOT ATTEMPT TO RELIGHT THE APPLIANCE FOR 3 MINUTES.

RUNNING IN

During initial use of a new Gazco appliance a strong odour will be encountered as various surface coatings become hot for the first time. Although these odours are harmless it is recommended that the appliance is operated on maximum for 4 to 8 hours in order to fully burn off these coatings. After this period the odours should then disappear.

If the odours persists, please contact your installer for advice.

During the first few hours of burning there may be discolouration of the flames. This will also disappear after a short period of use.

SERVICING

The appliance must be serviced every 12 months by a qualified Gas Engineer. In all correspondence always quote the Model number and the Serial number which may be found on the Commissioning Checklist (Installation Instructions).

INSTALLATION DETAILS

Your installer should have completed the commissioning sheet at the front of this book. This records the essential installation details of the appliance. In all correspondence always quote the Model number and Serial number.

HOT SURFACES

Parts of this appliance become hot during normal use.

Regard all parts of the appliance as a working surface.

Provide a suitable fire guard to protect young children and the infirm.

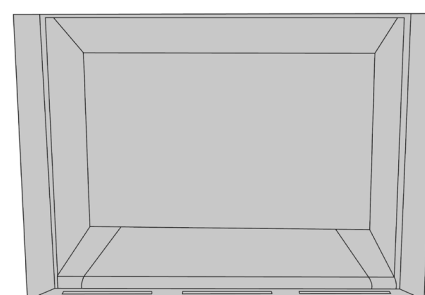

APPLIANCE WILL NOT LIGHT

If you cannot light the appliance:

Check and change the batteries in the remote handset.

Check and change the appliance batteries.

Consult your Gazco retailer or installer if the appliance still does not light.

INSTALLATION

APPLIANCE LOCATION

This appliance can be installed in four different ways:

- 1) Builder's opening with an Edge finish.
- 2) Builder's opening with a decorative front.
- 3) Stud work with an Edge finish.
- 4) Stud work with a decorative front.

This appliance must not be installed in a room that contains a bath or shower.

Combustible parts of the studwork must not be any closer than the minimum dimensions shown in the diagrams.

NOTE: These dimensions must be maintained even if the combustible materials is protected by non-combustible linings.

Do not pack the void around or above the appliance with insulation materials such as mineral wool.

The void into which the cassette is fitted must be ventilated to prevent a build up of heat. If the void is sealed then it will be necessary to fit vents on both sides at high levels with a minimum open free area of 150cm² each. These vents should take cold air from the room and return warm air back into the room.

A removable access hatch must be left in the side of the chimney breast for future servicing and inspection of the appliance.

Build the studwork chimney breast to the desired size. Ensure that the clearances to combustible materials is maintained.

SAFETY PRECAUTIONS

For your own and other's safety, you must install this appliance according to local and national codes of practice. Failure to install the appliance correctly could lead to prosecution. **Read these instructions before installing and using this appliance.**

These instructions must be left intact with the user.

Do not attempt to burn rubbish on this appliance.

Keep all plastic bags away from young children.

Do not place any object on or near to the appliance and allow adequate clearance above the appliance.

IF THE APPLIANCE IS EXTINGUISHED OR GOES OUT IN USE, WAIT 3 MINUTES BEFORE ATTEMPTING TO RELIGHT THE APPLIANCE.



IMPORTANT: REFER TO DATA BADGE AND TECHNICAL SPECIFICATION AT THE FRONT OF THE MANUAL TO ENSURE THE APPLIANCE IS CORRECTLY ADJUSTED FOR THE GAS TYPE AND CATEGORY APPLICABLE IN THE COUNTRY OF USE.

FOR DETAILS OF CHANGING BETWEEN GAS TYPES REFER TO SERVICING SECTION REPLACING PARTS.

UNPACKING

Remove the appliance from its packaging, and check that it is complete and undamaged.

Put the loose ceramic parts to one side so that they are not damaged during installation.

FLUE & CHIMNEY REQUIREMENTS

Note: This appliance must only be installed with the flue supplied.

The following must be adhered to:

The flue must be sited in accordance with BS5440: Part 1 (latest edition).

Fit a guard to protect people from any terminal less than 2 metres above any access such as level ground, a balcony or above a flat roof.

All vertical and horizontal flues must be securely fixed and fire precautions followed in accordance with local and national codes of practice.

Two types of flue terminals are available, horizontal and vertical.

To measure for a horizontal terminal decide on the terminal position.

Measure the height from the top of the appliance to the centre of the required outlet.

For minimum and maximum flue dimensions see relevant sections.

A restrictor may be required. Refer to Technical Specifications.

Allow enough room either above or to the side of the appliance to assemble the flue on top.

Assemble a horizontal flue in the following order:

- Vertical section
- 90° elbow
- Horizontal plus terminal

Support the opening of a masonry installation with a lintel.

Only the horizontal terminal section can be reduced in size.

TIMBER FRAMED BUILDINGS

It will be necessary to provide additional clearance when the flue passes through a wall containing any combustible materials so as to prevent a fire hazard.

The hole through which the flue will pass, must have a steel sleeve which is positioned so that an air gap of at least 25mm is maintained between the outer surface of the flue, and any part of the sleeve.

For further guidance on the installation of gas appliances in timber framed buildings, contact your local buildings control authority.

GAS SUPPLY

This appliance is intended for use on a gas installation with a governed meter.

Make sure local distribution conditions (identification of the type of gas and pressure) and the adjustment of the appliance are compatible before installation.

Ensure the gas supply delivers the required amount of gas and is in accordance with the rules in force.

Soft copper tubing can be used on the installation and soft soldered joints outside the appliance and below the firebed.

A factory fitted isolation device is part of the inlet connection; no further isolation device is required.

All supply gas pipes must be purged of any debris that may have entered prior to connection to the appliance.

The gas supply enters through the silicone panel located on the LEFT-HAND side on the rear of the outer box. Slit with a sharp knife prior to passing the supply pipe through.

The gas supply must be installed in a way that does not restrict the removal of the appliance for servicing and inspection.

VENTILATION

The installation of this product requires no additional ventilation modifications to the building.

However, it will be necessary to ensure the housing for the appliance has vents provided to allow air to circulate and prevent overheating.

TECHNICAL SPECIFICATION

This appliance has been certified for use in countries other than those stated. To install this appliance in these countries, it is essential to obtain the translated instructions and in some cases the appliance will require modification. Contact Gazco for further information.

PACKING CHECKLIST

Qty	Description	Fixing kit containing
1 x	Cassette and burner assembly	1 x Instruction manual
1 x	Back panel	6 x Woodscrews
1 x	LH side panel	6 x Wall plugs
1 x	RH side panel	1 x Self adhesive foam strip
1 x	Log set (6 logs)	1 x Handset
1 x	Blanking Plate	4 x AA cell batteries
		1 x 9v cell battery
		1 x Battery Holder

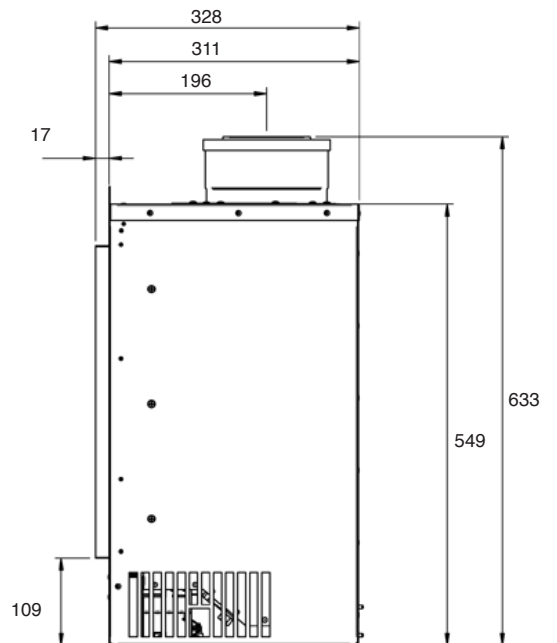
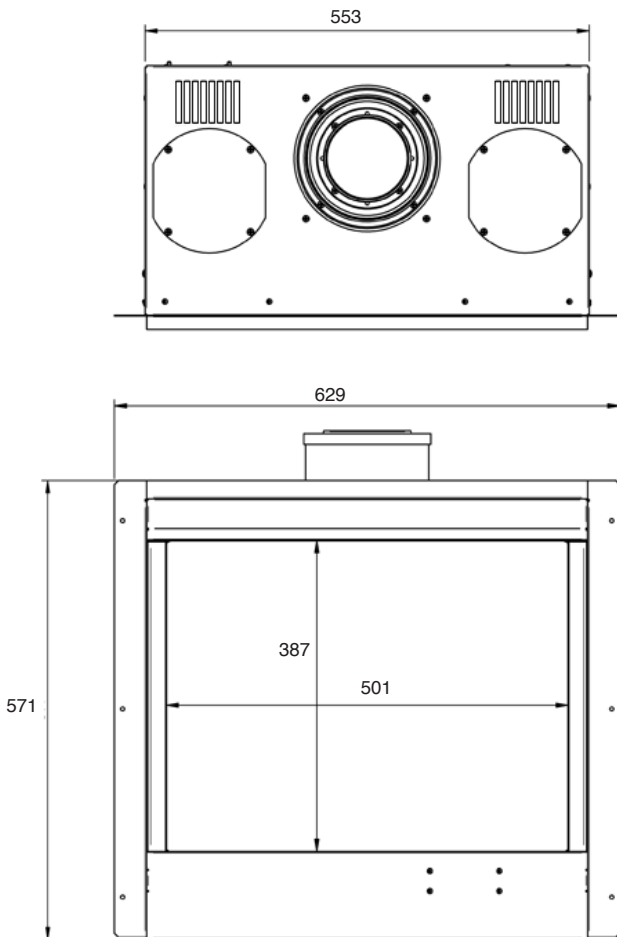

TECHNICAL SPECIFICATION

Covering the following models:

RIVA2 500 NAT GAS	RIVA2 500 LPG
134-249	134-401

MODEL	GAS CAT.	GAS TYPE	WORKING PRESSURE	AERATION	INJECTOR	GAS RATE M ³ /H	INPUT KW (GROSS)		COUNTRY
							HIGH	LOW	
Riva2 500	I ₂ H	Natural (G20)	20mbar	2 x 7.5mm Ø	375	0.552	5.8	2.9	GB, IE
Riva2 500	I ₃ P	Propane (G31)	37mbar	2 x 16mm Ø	125	0.211	5.6	2.9	GB, IE
Efficiency Class 1 - 93.9% / NO_x Class 3									
Flue Outlet Size Ø 100mm									
Flue Inlet Size Ø 152mm Ø									
Gas Inlet Connection Size Ø 8mm									

i The net efficiency of this appliance has been measured as specified in EN613:2001 and the result after conversion to gross using the appropriate factor from Table E4 of SAP 2012 is 84.6% (Nat Gas) and 86.5% (LPG). The test data has been certified by Kiwa Nederland BV. The gross efficiency value may be used in the UK Government's Standard Assessment Procedure (SAP) for energy rating of dwellings.

RESTRICTOR REQUIREMENT - VERTICAL & HORIZONTAL FLUE SPECIFICATION

Vertical flue height from top of appliance	Horizontal length	Restrictor size
500mm - 999mm	Up to 500mm	N/A
1000mm - 1499mm	Up to 1000mm	N/A
1500mm - 2499mm	Up to 5000mm	70mm
2500mm - 3000mm	Up to 5000mm	60mm

TOP EXIT - VERTICAL ONLY INCLUDING OFFSET

RIVA2 500	
Vertical flue height from top of appliance	Restrictor size
3000mm - 5999mm	52mm
6000mm - 10000mm	47mm

SITE REQUIREMENTS

FLUE OPTIONS

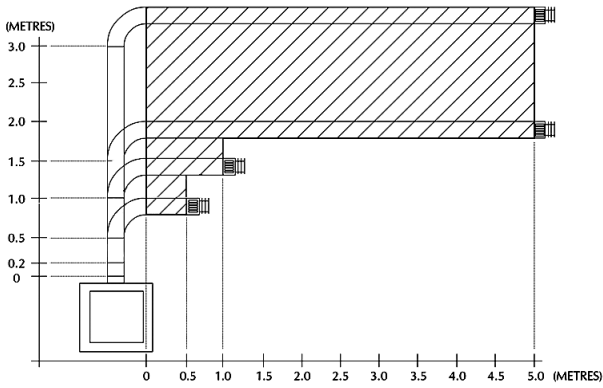

Start of bend to centre line of horizontal flue 170mm. Centre line of vertical flue to end of bend 220mm.

TOP FLUE UP AND OUT KIT 8509/ 8509AN

Vertical from the top of the appliance then horizontally out, see Diagram 2a. The basic kit comprises:

- 1 x 500mm terminal length
- 1 x 200mm vertical length
- 1 x 90 degree elbow
- 1 x 500mm vertical length
- 1 x wall plate
- 1 x 60mm restrictor
- 1 x 70mm restrictor
- 1 x 75mm restrictor
- 4 x fixing screw

This kit provides the minimum materials. Extra lengths can be added to the vertical and horizontal sections.

Refer to Installation Instructions, Technical Specification to identify when to use a restrictor.

TOP FLUE UP AND OUT WITH ADDITIONAL BEND

Any additional bend may be used on the horizontal section (either 45° or 90°), but the overall horizontal flue run will be reduced. Refer to Diagram.

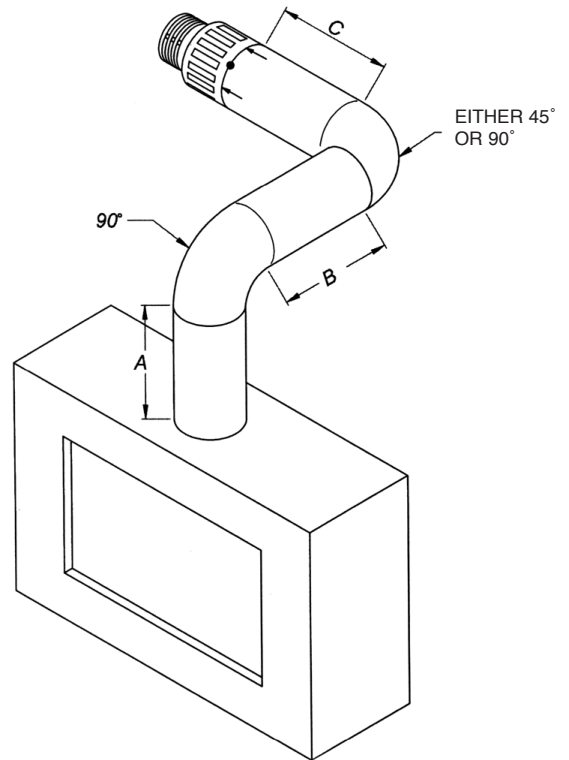

When A = 1.0 to 1.499 metres B + C = 1.0 metres maximum
When A = 1.499 metres to 3.0 metres B + C = 4.0 metres maximum

SITE REQUIREMENTS

TOP FLUE VERTICAL KIT (8524/8524AN)

Vertical from the top of the appliance, see Diagram.
A minimum vertical rise 3m (9'10") to a maximum 10m (32'10").
The basic kit comprises:

- 2 x 1m lengths
- 1 x 1m terminal length
- 1 x 70mm restrictor
- 1 x 60mm restrictor
- 1 x 52mm restrictor
- 1 x 47mm restrictor

Extra lengths may be added from the table.

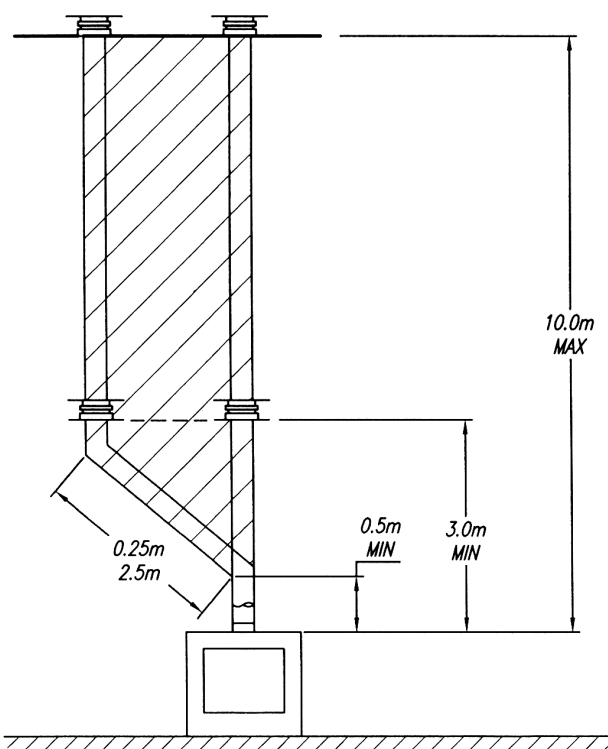

TOP FLUE VERTICAL OFFSET KIT (8530/8530AN)

Used with kit 8524. A minimum rise of 500mm (19 1/2") is required to the first bend.

OPTIONAL EXTRA FLUE LENGTHS AND BENDS

All flue components are 150mm diameter (6")

NOMINAL LENGTH	ACTUAL LENGTH	STAINLESS FINISH	ANTHRACITE FINISH
200mm	140mm	8527	8527AN
500mm	440mm	8528	8528AN
1000mm	940mm	8529	8529AN
40° Bend	N/A	8507	8507AN
90° Bend	N/A	8508	8508AN

NOTE: The following areas need careful consideration.

- a) Terminal positions
- b) Flue supports
- c) Weatherproofing
- d) Fire precautions

For all the above options, local and national codes of practice must be adhered to.

CHIMNEY RENOVATION KIT (928-315)

Details of the Chimney Renovation Kit are available in the separate installation instructions - PR2073 Chimney Renovation Kit instructions.

SITE REQUIREMENTS

APPLIANCE LOCATION



If fitting this appliance with a decorative frame (excluding the Ellingham front) it cannot be installed with the base of the appliance less than 150mm from the floor level. The frame requires a minimum clearance to allow air to circulate.

If this appliance is fitted less than 150mm from the floor, then it will require a hearth to protect the floor. The hearth should have a minimum dimension of 12mm thick, projecting 300mm in front and 150mm either side of the appliance.

The minimum opening dimensions are:

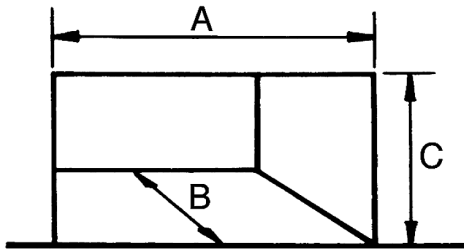

DIMENSION	Riva2 500
A	565
B	350
C	560

This appliance must not be installed in a room that contains a bath or shower.

NOTE: If using natural materials for the back panel of the fireplace, it is recommended that it is constructed from three or more sections to prevent cracking. Resin-based materials may not be suitable. This appliance is an effective heat producer and attention must be paid to the construction and finish of the fireplace.

This appliance is not suitable for installation onto a combustible wall; all combustible materials must be removed from the area shown.

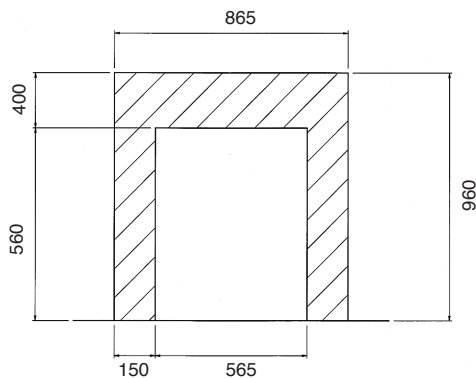

STUDWORK INSTALLATION



Gazco recommend building the enclosure from the following materials:

Metal Studwork

Non-combustible board:

Masterboard or Promafour - NOT PINK BOARD

Heat Resistant Plaster: Purimacho (any spider cracks that develop after installation will need to be rubbed down and refilled with Purimacho heat resistant filler to stabilise).

Ensure all distances to combustible materials are maintained.

If a studwork installation is used (eg. wooden framework and plasterboard), combustible parts of the studwork must not be any closer than the minimum dimensions shown in the diagrams. NOTE: These dimensions must be maintained even if the combustible materials is protected by non-combustible linings.

Do not pack the void around or above the appliance with insulation materials such as mineral wool.

The void into which the cassette is fitted must be ventilated to prevent a build up of heat. If the void is sealed then it will be necessary to fit 2 vents at high levels with a minimum open free area of 150cm² each. These vents should take cold air from the room and return warm air back into the room.

A removable access hatch must be left in the side of the chimney breast for future servicing and inspection of the appliance.

Build the studwork chimney breast to the desired size. Ensure that the clearances to combustible materials is maintained.

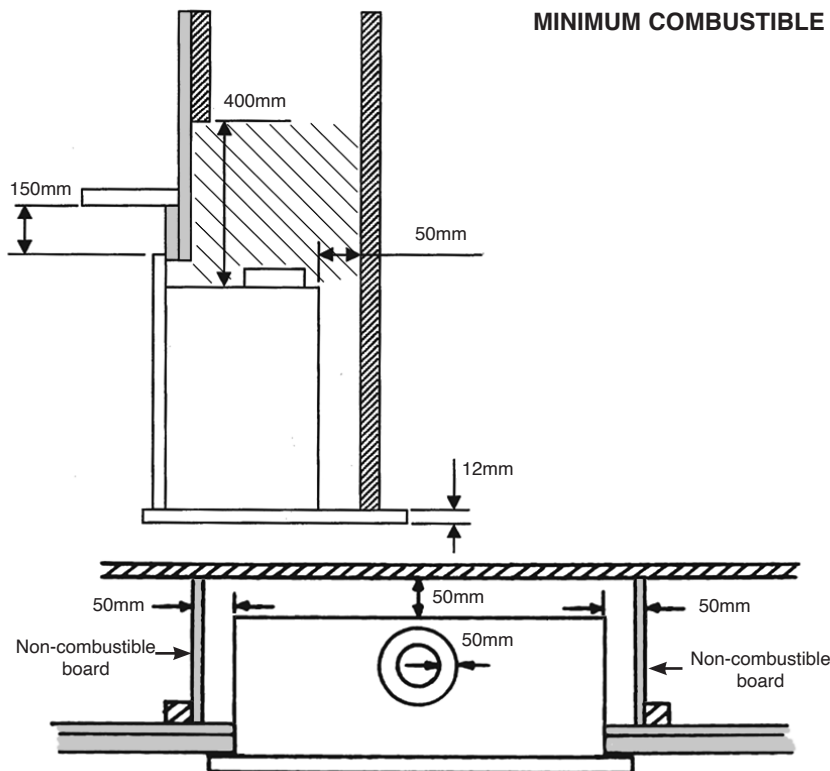

It is recommended that a marble slip or similar material is used when fitting cassette fireplaces into a plastered surface, in order to allow for heat dissipation. Also allow adequate time for newly plastered areas to dry out. Rapid drying can create cracks. If in doubt, seek the advice of a professional plasterer.

Parts of this appliance become hot during normal use. It is therefore recommended that a suitable fire guard be used for protection of young children and the infirm.

MASONRY INSTALLATION

Please note this appliance has been primarily designed for studwork applications. However, there are circumstances where the appliance could be installed in a block or brickwork fireplace using different methods and materials for the final effect.
THIS VOID MUST BE VENTED TO PREVENT HEAT BUILD UP AROUND THE APPLIANCE.

This appliance is not suitable for installation onto a combustible wall. Remove all combustible material from the area shown, see Diagram.

Create a Builders Opening in chimney breast to the required size. Ensure that the clearances to combustible materials is maintained.

In addition to constructing the Builder's Opening to the required size each side must have a high vent with a minimum open free area of 150cm² each to allow convection air to travel around the product.

The high vent should be within the 500mm gap above.

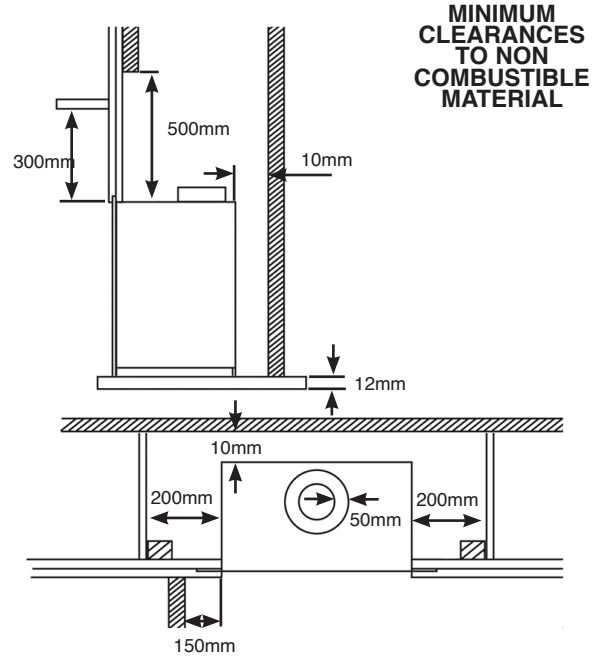

Ideal Masonry Installation

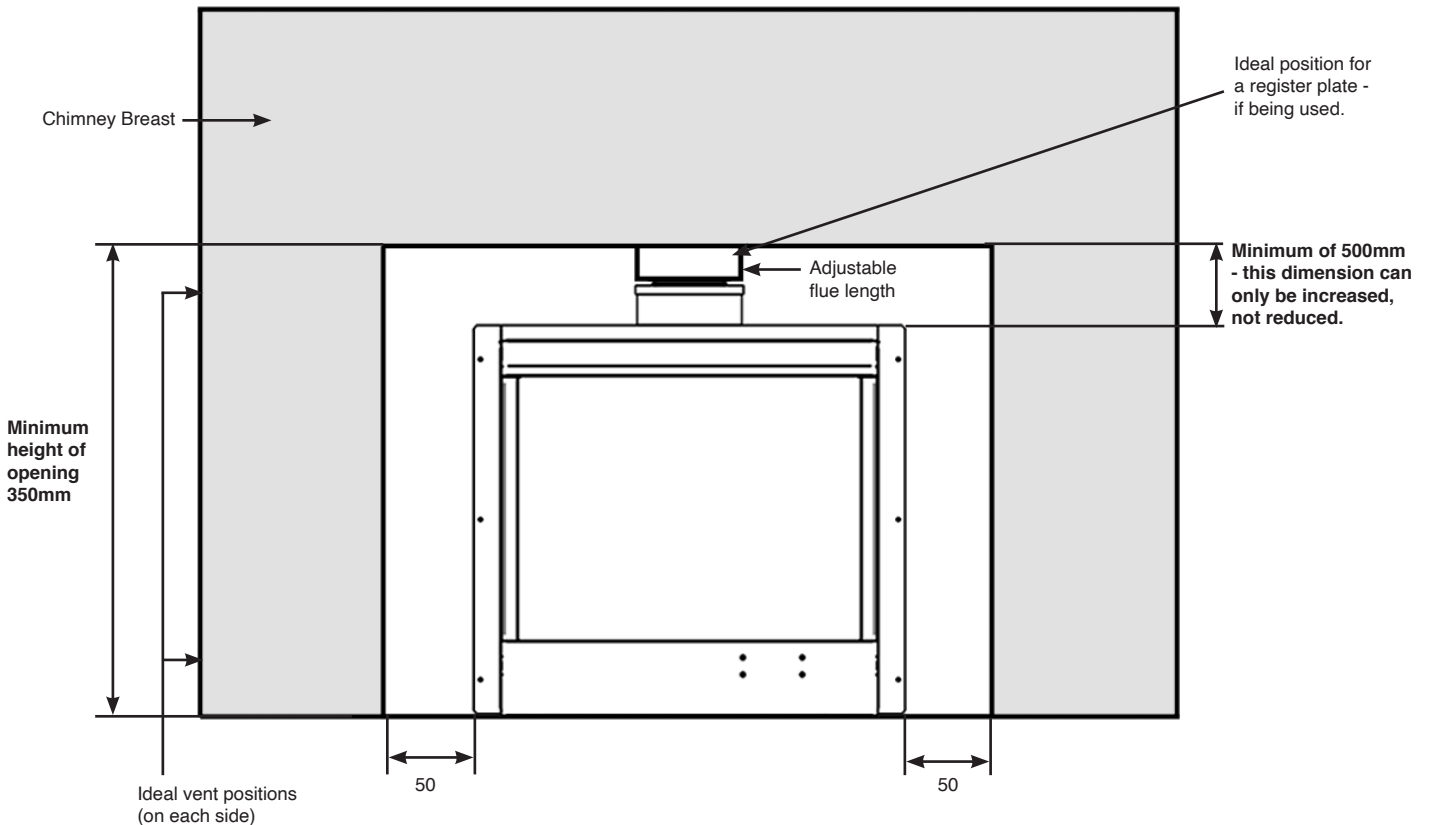

PRE-INSTALLATION

REMOVING THE GLASS FRAME

Remove the glass door by removing the 2 side trims. These are held on by magnets.

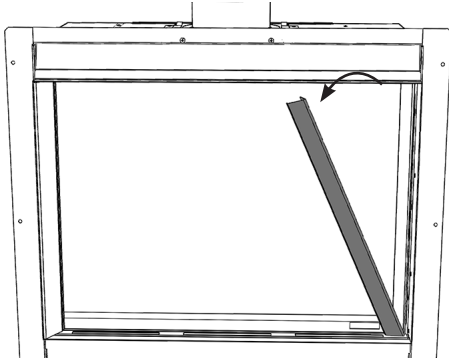

Lift out the bottom slotted trim. Note the orientation of the battery box for reassembly.

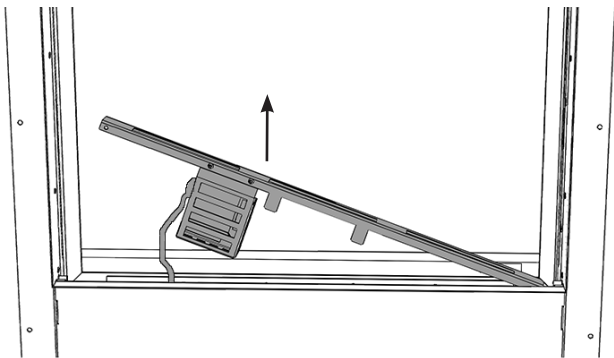

Disconnect the battery lead from the battery pack attached to the lower slotted trim.

Remove the screws at the base of the glass frame.

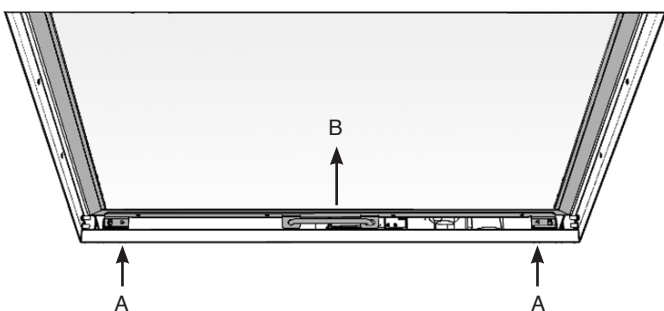

Pull up the handle at the front.

Whilst supporting the top, lift the glass frame using the handle, up and over the lower edge.

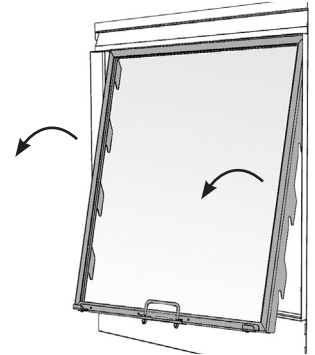

Remove the 2 screws at the front of the burner unit.

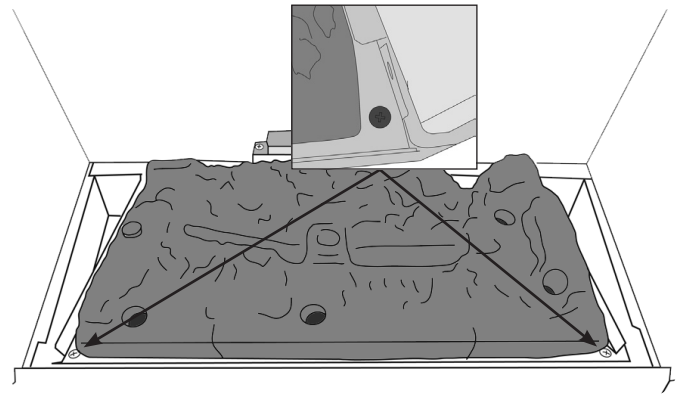

Slide the burner unit to the right, pull slightly forward and lift from the back. Carefully remove through the front of the appliance. Place carefully to one side.

Note: When reinstalling the burner unit ensure that the tabs at the back of the burner tray engage in the channel under the back panel.

Remove the 4 screws to remove the access plate.

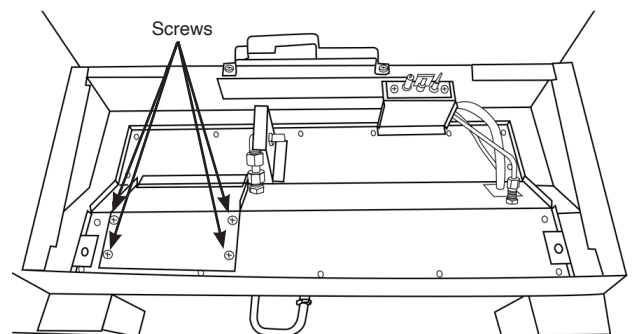

The gas supply enters through the silicone panel located on the left-hand side on the rear of the outer box; this will need to be slit with a sharp knife prior to passing the supply pipe through.

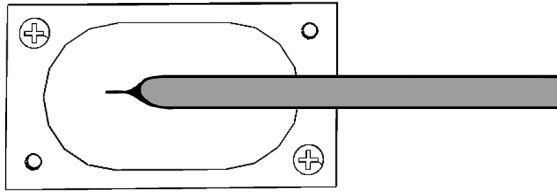

Note: The isolation elbow needs to be attached to the gas pipe before installation.

FLUE ASSEMBLY

For additional information please refer to Site Requirements section.

TAKE CARE WHEN MARKING OUT FOR THE FLUE AS IT IS DIFFICULT TO MOVE AFTER INSTALLATION. IF A RESTRICTOR IS REQUIRED FIT THIS BETWEEN THE SMALL OUTLET SPIGOT AND THE AIR DUCT. REFER TO TECHNICAL SPECIFICATIONS FOR RESTRICTOR SIZE.

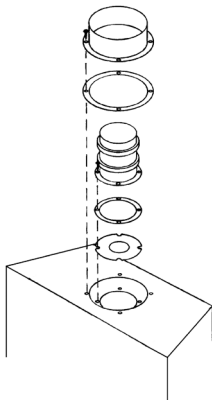

A 152mm (6") diameter hole in the wall is required to install the flue. This can be achieved by using either:

- Core drill
- Hammer and chisel

Drill small holes around the circumference when using method b). Make good both ends of the hole.

Allow enough room either above or to the side of the appliance to assemble the flue on top.

Assemble a horizontal flue in the following order:

- Vertical section
- 90° elbow
- Horizontal plus terminal

Support the opening of a masonry installation with a lintel.

Only the horizontal terminal section can be reduced in size.

To find the length:

Measure from the outside of the wall to the stop on the 90° elbow.

Add 10mm to the outlet end.

Measure from the edge of the slots closest to the wall.

Mark around the flue.

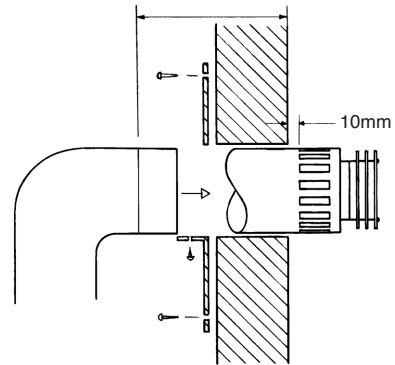

A wall plate is supplied to fix the flue to the wall:

Bend the tab to 90°.

Assemble the plate onto the flue but do not secure to wall until the flue is fully assembled.

The cardboard fitment in the terminal is used to support the flue whilst it is cut to length. **ONCE CUT TO SIZE REMOVE THE CARDBOARD REMNANT.**

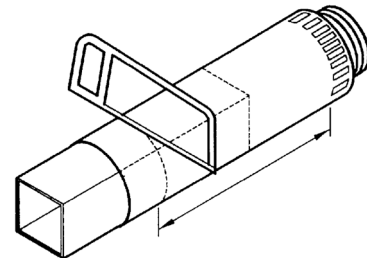

MASONRY CHIMNEY INSTALLATION

The appliance can be installed into brick and block construction or chimney breast and finished with a plasterboard and skimmed finish.

This product can also be used in conjunction with the Gazco Chimney Renovation kit, see separate instructions for details.

There are 2 methods of installation into a masonry chimney

Edge finish Installation.

Installation with a decorative front.

Carefully read the relevant section for the installation method required.

EDGE FINISH INSTALLATION

This method is designed so that non-combustible board can be taken right up to the edge of the flange of the appliance.

Fix the self adhesive foam seal around the back of the fixing flange of the appliance.

Prepare the flue connection using the chosen method described.

Connect the flue and install the appliance into the aperture. At the same time ensure that the gas pipe passes through the silicon panel at the back of the appliance.

Secure the appliance through the 6 fixing holes using the screws provided.

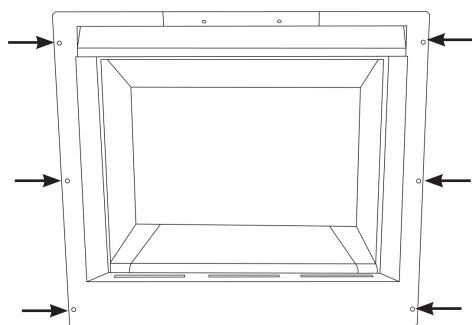

Build the chimney breast up to coincide with the edge, allowing for the front to be skimmed level.

Fit non-combustible board to the chimney breast around the appliance, using the distance to combustibles detailed.

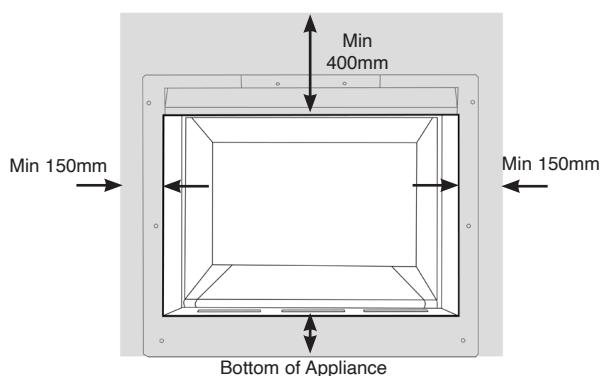

Fit plasterboard to the remaining of the chimney breast front.

Apply a heat resistant plaster around the appliance using the distance to combustibles detailed.

Apply a plaster finish to remaining chimney breast front.

INSTALLATION WITH A DECORATIVE FRONT

Fix the self adhesive foam seal around the back of the fixing flange of the appliance.

Prepare the flue connection using the chosen method described.

Connect the flue and install the appliance into the aperture. At the same time ensure that the gas pipe passes through the silicon panel at the back of the appliance.

Secure the appliance through the 6 fixing holes using the screws provided.

The appliance flange should sit flush to the brickwork and the edge should sit proud of the wall.

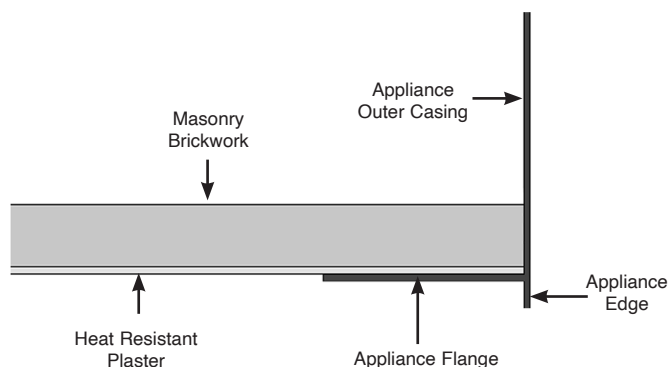

The subframe for the decorative front can now be fitted by following the instructions supplied with the Front.

NOTE: THE SUBFRAME MUST SIT FLUSH TO THE WALL LEVEL WITH THE APPLIANCE FLANGE.

ENCLOSURE CONSTRUCTION

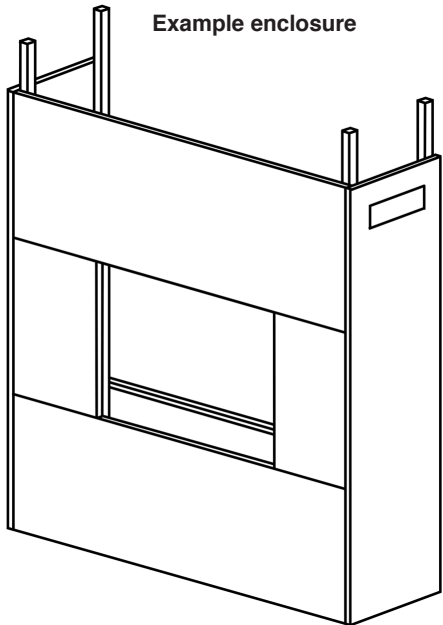

VENTILATION



The void into which the cassette is fitted must be ventilated to prevent a build up of heat. If the void is sealed then it will be necessary to fit high level vents on both sides of the enclosure with a minimum free area of 150cm² each. These vents should take cold air from the room and return warm air back into the room.

Gazco recommend building the enclosure from the following materials:

Metal Studwork

Non-combustible board:

Masterboard or Promafour - NOT PINK BOARD

Heat Resistant Plaster: Purimacho (any spider cracks that develop after installation will need to be rubbed down and refilled with Purimacho heat resistant filler to stabilise).

Ensure all distances to combustible materials are maintained

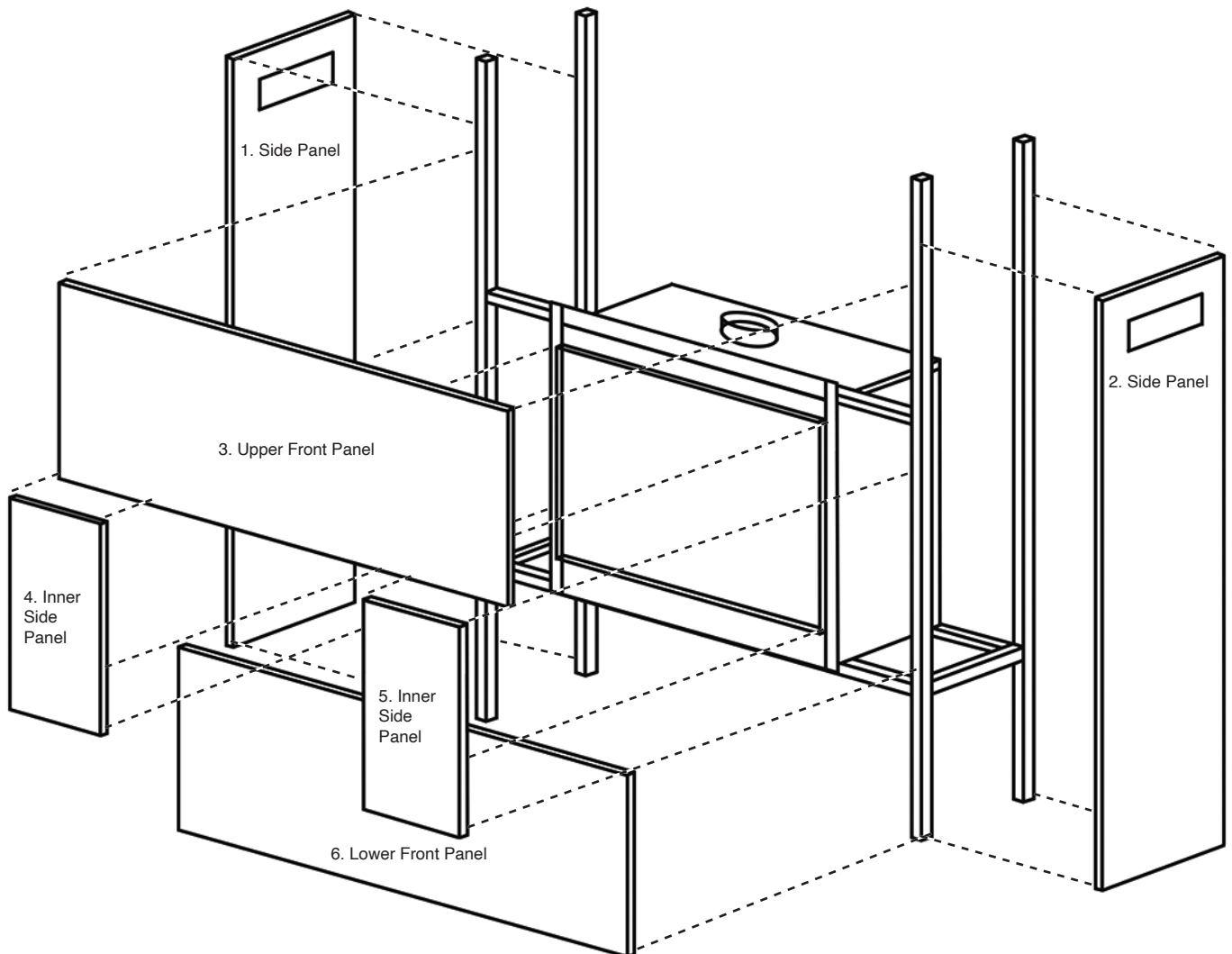

CUTTING TEMPLATES

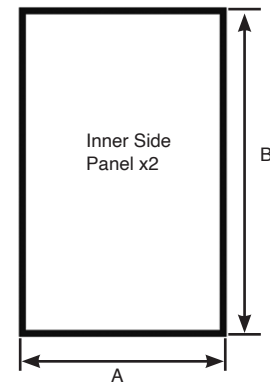
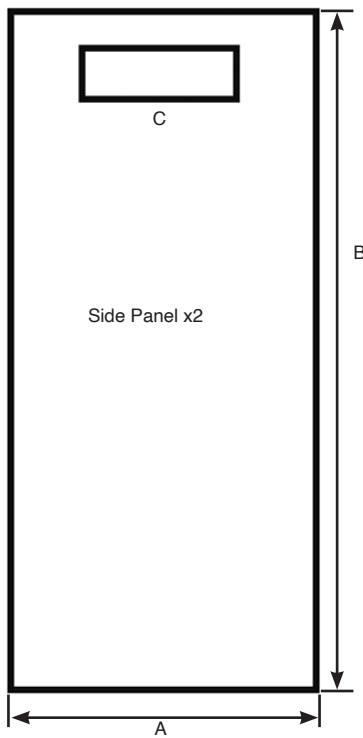
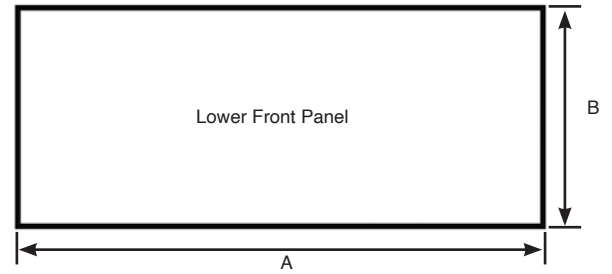
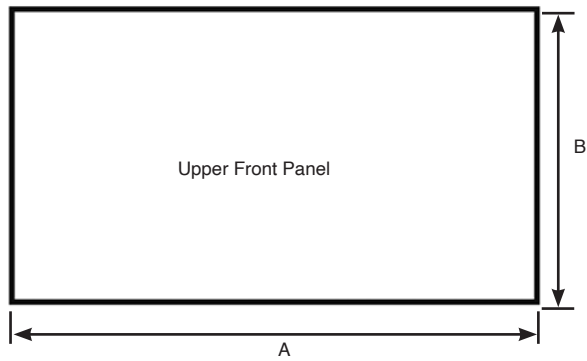

PANEL	A (MIN)	B (MIN)	C
Upper Front Panel	853mm	400mm	-
Lower Front Panel	853mm	109mm No Frame 150mm - Decorative Frame	-
Side Panel	361mm	896mm No Frame 937mm - Decorative Frame	Minimum 150cm ² free area
Inner Side Panel	150mm	387mm	-

EDGE FRAME INSTALLATION

Fix the self adhesive foam seal around the back of the fixing flange of the appliance.

④

①

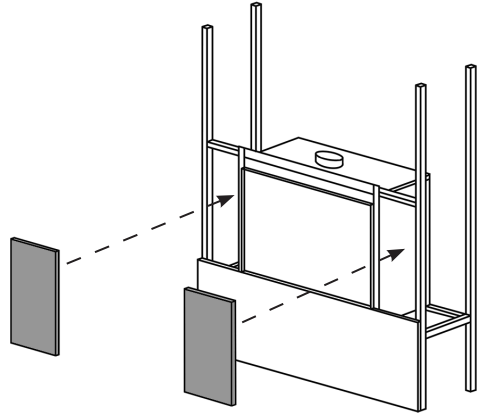
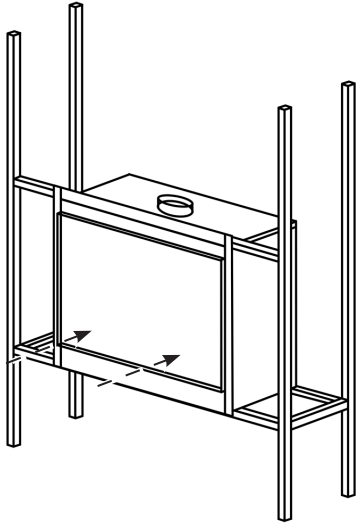

⑤

②

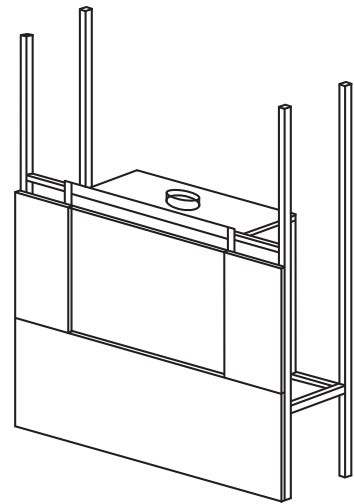
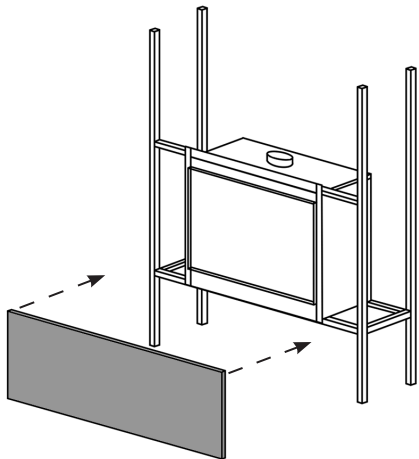

⑥

③

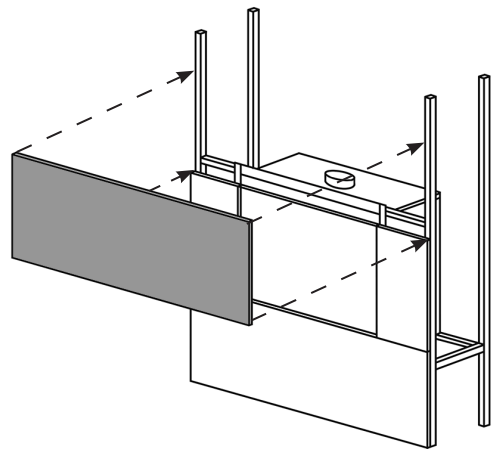
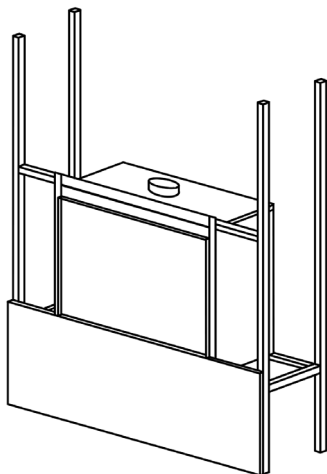

7

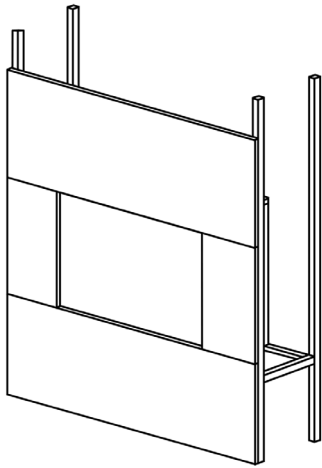

8

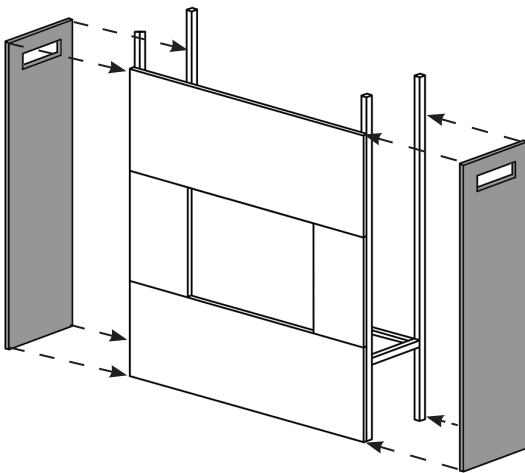

9

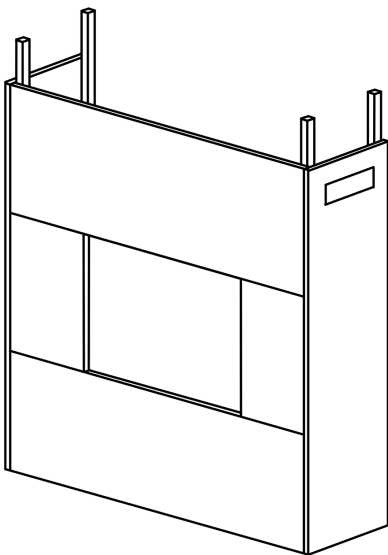

DECORATIVE FRAME INSTALLATION

IMPORTANT: BEFORE THE INSTALLATION OF THE DECORATIVE FRONT ENSURE THAT THE WALL ABOVE AND TO THE SIDES OF THE APPLIANCE IS SUITABLY CONSTRUCTED FOR THE FIXINGS TO SUPPORT THE WEIGHT OF THE FRONT. IF THE WALL IS CONSTRUCTED FROM PLASTERBOARD OR SIMILAR, IT IS ESSENTIAL THAT BATTERNS ARE LOCATED TO THE SIDES OF THE APPLIANCE IN THE FIXING AREA TO PROVIDE STRENGTH TO THE FIXINGS.

When constructing a studwork installation it is essential to observe the clearances to combustibles but make provision for the frame fixings.

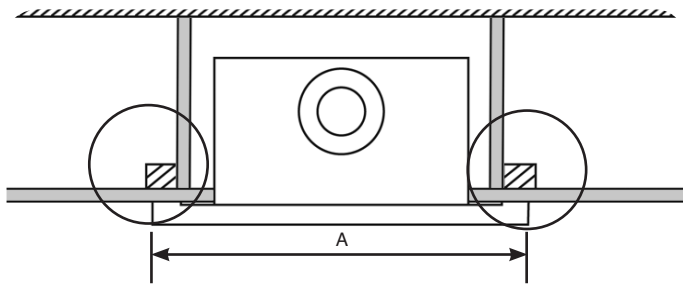

This diagram shows the minimum clearance position when installing the appliance into studwork - it is vital to ensure the opening is wide enough to accommodate the fixings for the front.

Distance between front fixings:

FRAME OPTION	A
Verve XS	677.5
Icon	725
Ellingham	739

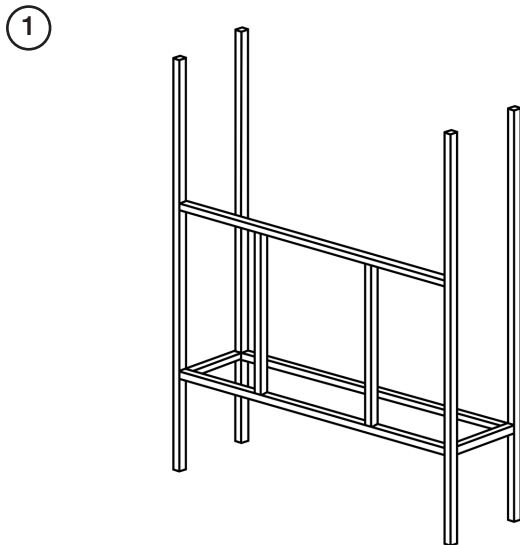
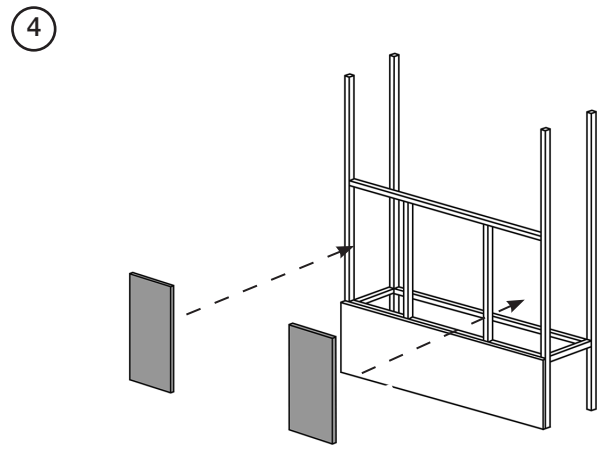
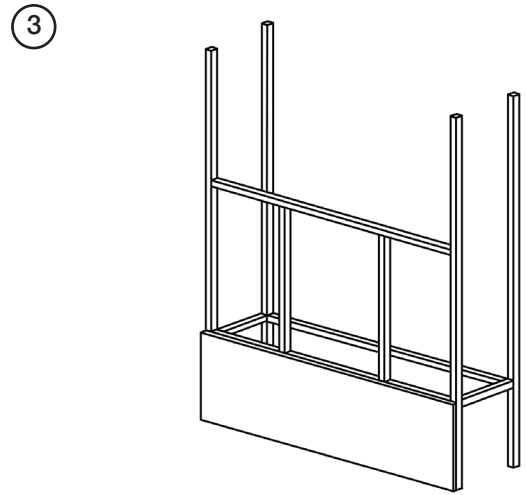
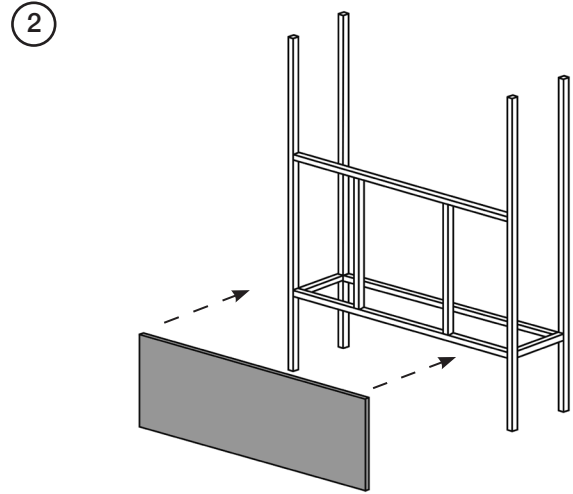

5

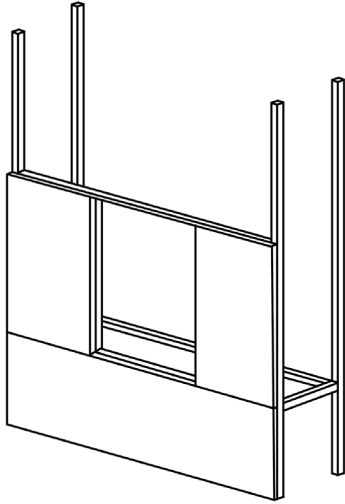

8

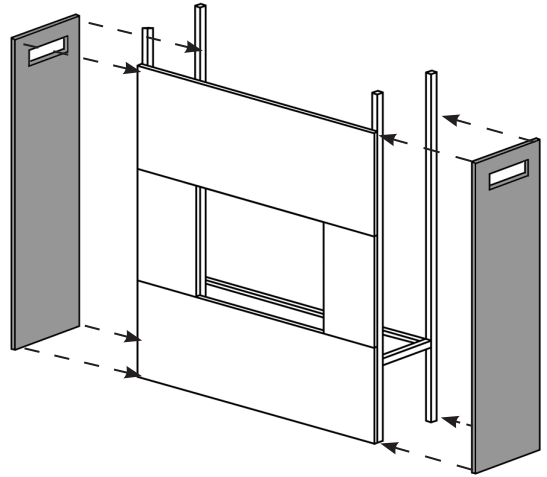

6

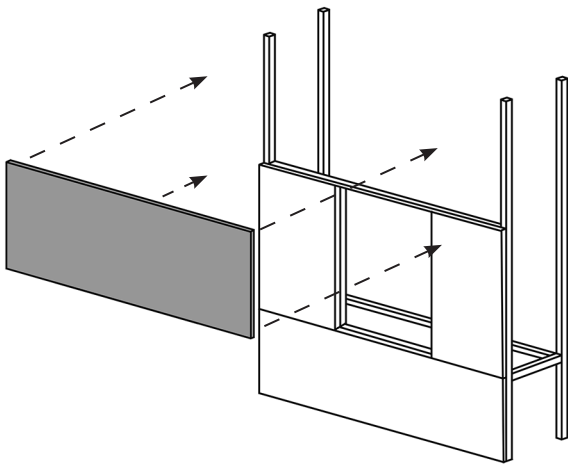

9

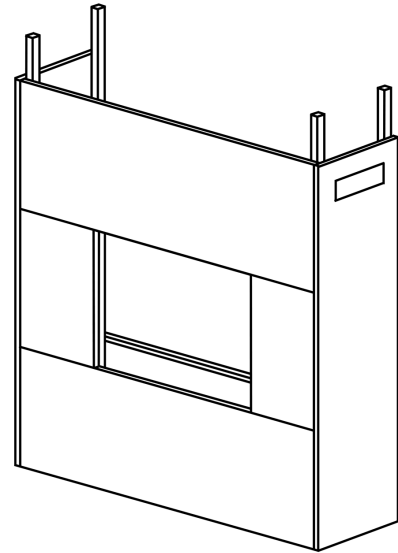

7

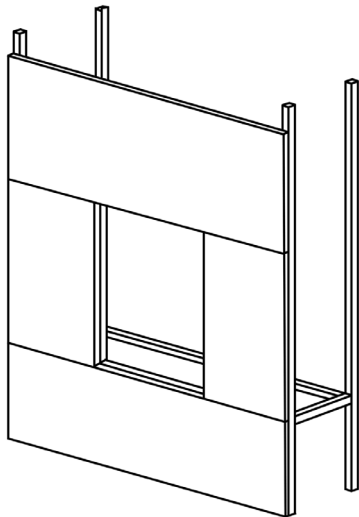

Fix the self adhesive foam seal around the back of the fixing flange of the appliance.

10

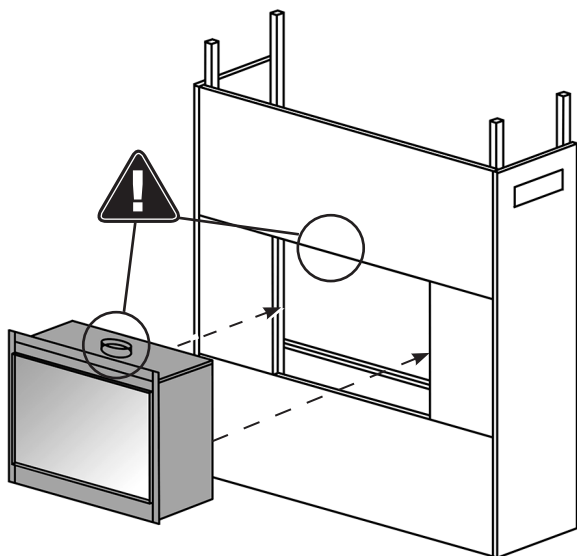

11

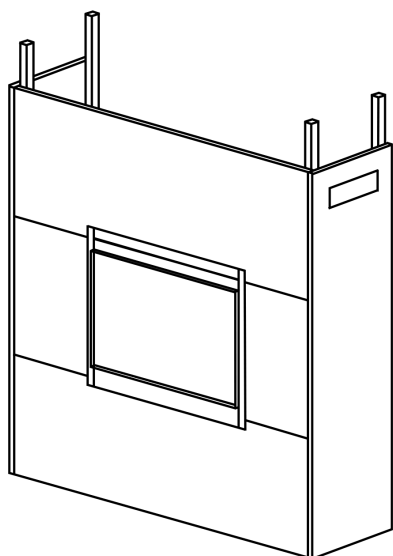

GAS SUPPLY

Remove the compression elbow from the appliance and connect it to the gas supply pipe.

As the appliance is fitted into the enclosure:

Pass the elbow and supply pipe through the opening on the LEFT HAND side.

PURGE THE SUPPLY PIPE. This is essential to expel any debris that may block the gas controls.

Connect the elbow to the appliance inlet pipe.

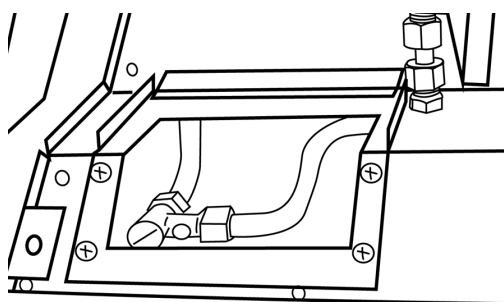

GAS SOUNDNESS PRESSURE CHECK

Connect a suitable pressure gauge to the test point located on the inlet fitting.

Pass the pressure pipe under main control assembly and out through the gap inside the outer casing.

Refit the burner unit, turn the gas supply on and perform a pressure drop test to check for leaks in the installation. Light the appliance, turn to maximum and check that the supply pressure is as stated on the databadge. Turn the gas off and replace the test point screw, turn the gas on and check the test point for leaks.

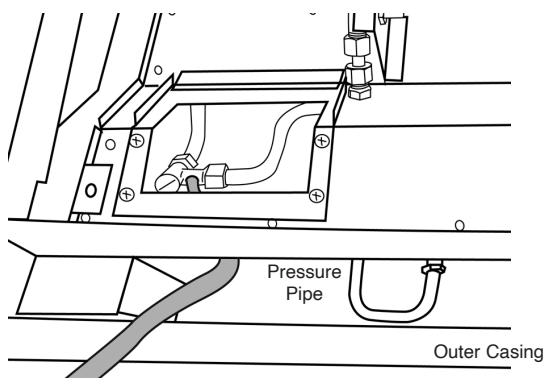

Check the function of the handset, if there is no communication between the remote control and the appliance, see Commissioning Section.

FITTING THE LINERS

The baffle must be removed before the liners can be fitted.

The baffle is held in place by 5 screws, 3 at the front and 2 at the rear. The rear screws sit between slotted tabs, once the front screws are removed, loosen the rear screws and slide the baffle forward to remove.

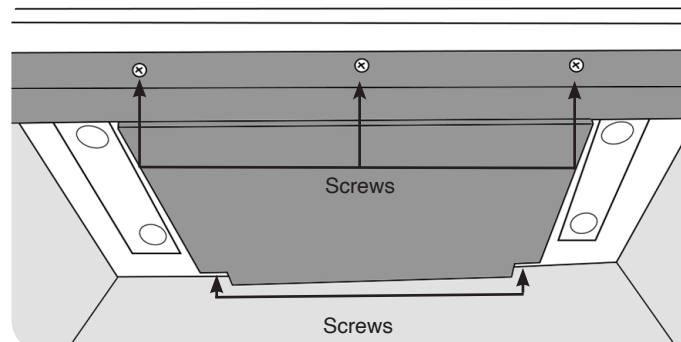

The baffle can now be removed by lowering the front edge and pulling forward through the front of the appliance.

TAKE CARE NOT TO DAMAGE THE SIDE PANELS

i BLACK REED, BRICK EFFECT AND LEDGESTONE LINERS

These lining panel options are available for this product and contains Refractory Ceramic Fibre (RCF), a material which is commonly used for this application.

RCF waste is classed as stable, non-reactive hazardous waste and may be disposed of at a licensed landfill site.

If replacing these items do not break them up. Seal within heavy duty polythene bags and label as RCF waste.

Protective clothing is not required when handling these articles.

If the Liners are visibly broken Gazco recommend using gloves and a face mask to remove the pieces and remove any dust accumulated in and around the appliance before and after working on it with a HEPA filtered vacuum.

If any concerns remain contact Gazco Technical Customer Services to obtain the manufacturers Safety Data Sheet.

Undo the 2 screws to remove the rear log support bracket.

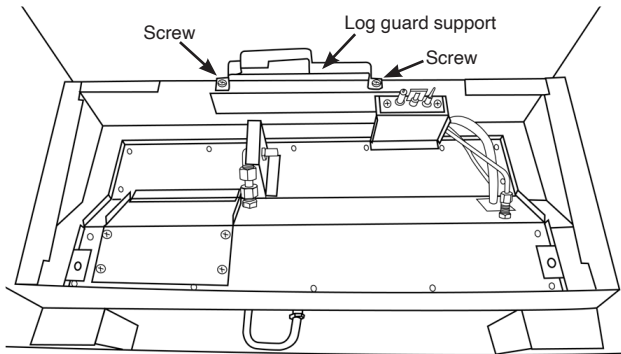

Carefully fit the back liner by twisting slightly to insert through the front of the appliance and lifting over the pilot, see Diagram 38. **Take care not to damage the pilot.**

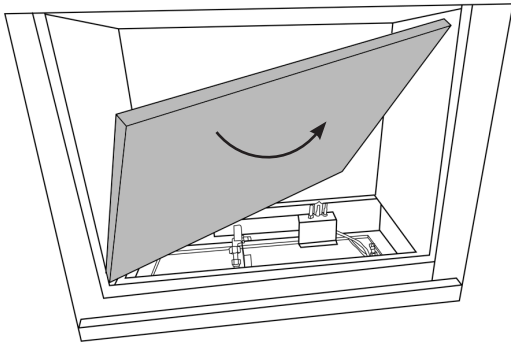

To fit the Right Hand liner insert through the front of the appliance tilting the top inwards towards the centre of the firebox before lowering into position.

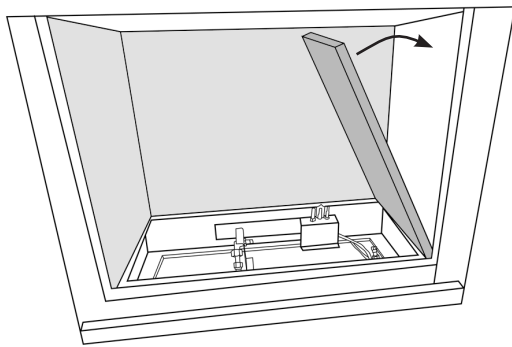

To fit the Left Hand liner insert through the front of the appliance tilting the top inwards towards the centre of the firebox before lowering into position.

The 2 side liners also support the rear panel.

Insert the baffle through the front of the firebox.

Replace the 3 screws at the front of the baffle and 2 at the back, to secure it to the roof of the firebox.

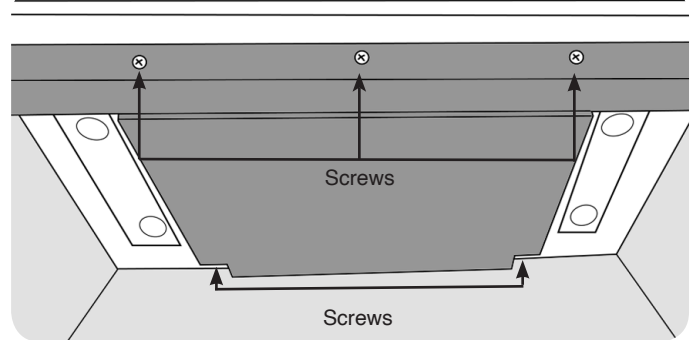

Replace the burner unit.

Note: When reinstalling the burner unit ensure that the tabs at the back of the burner tray engage in the channel under the back panel.

Replace the rear log support bracket and secure with the 2 screws..

Fit the 2 lower side panels.

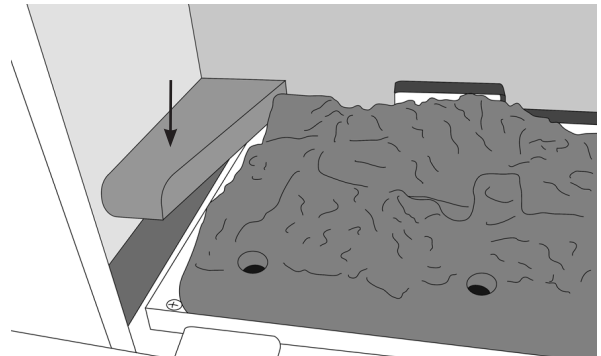

LOG LAYOUT

LOGS MUST BE POSITIONED ACCORDING TO THE FOLLOWING INSTRUCTIONS TO GIVE THE CORRECT FLAME EFFECT.

Ensure the Burner Tray and Log Burners are clean and free from any debris.

The main components are clearly individually labelled.

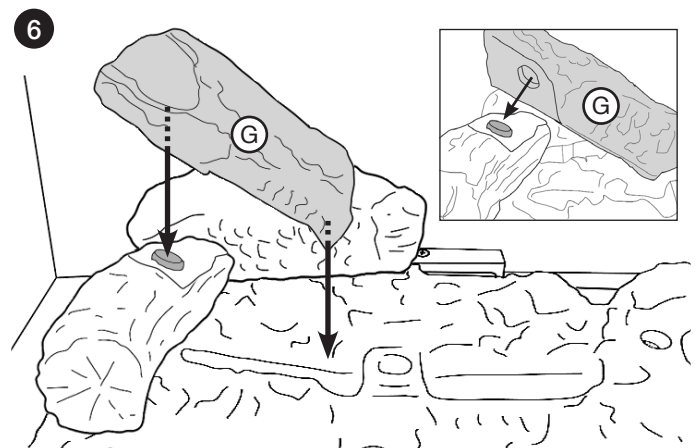
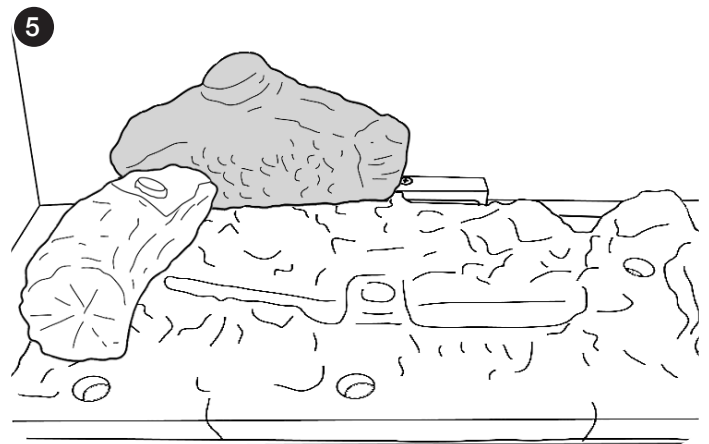
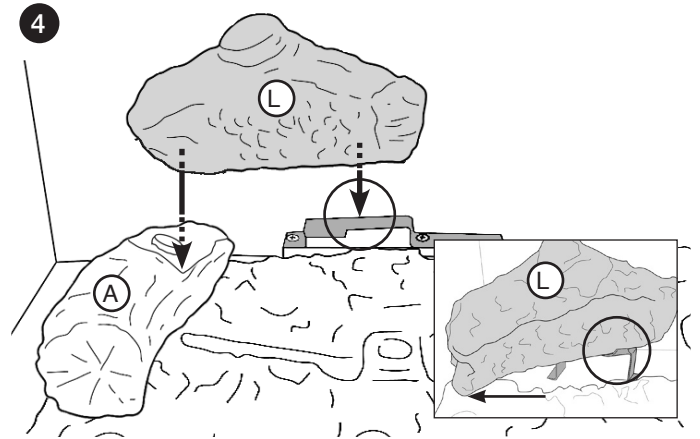
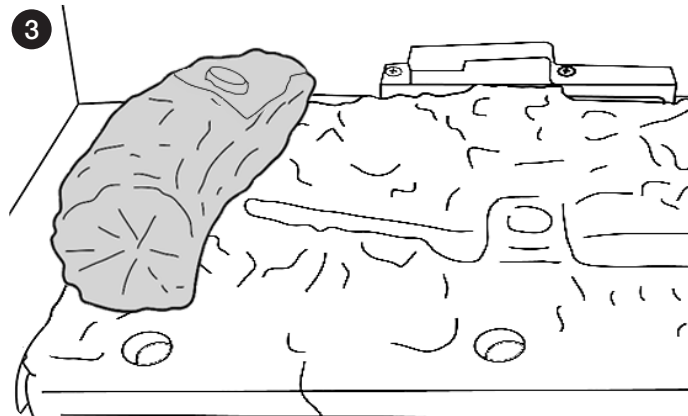
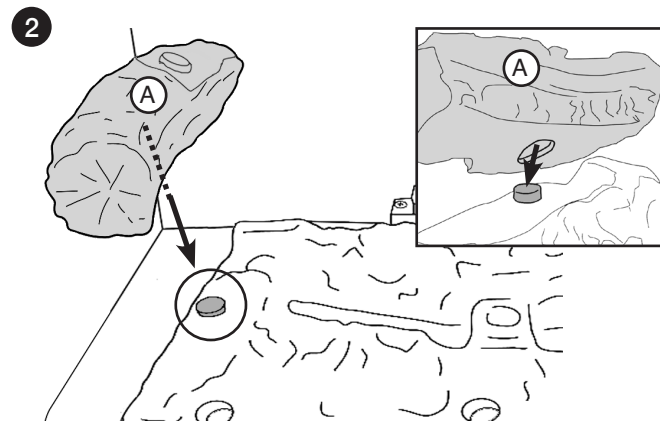
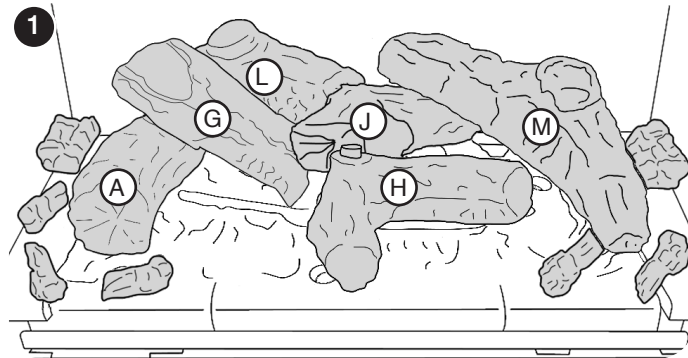

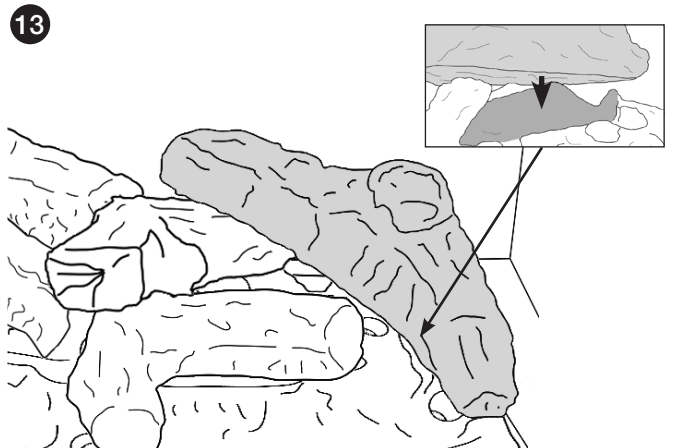
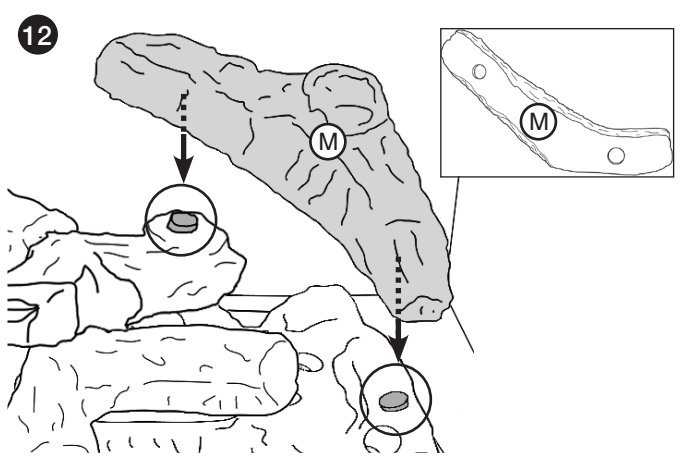
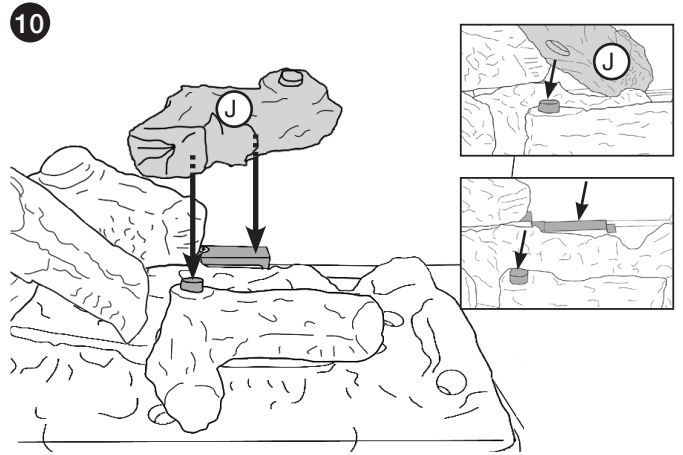
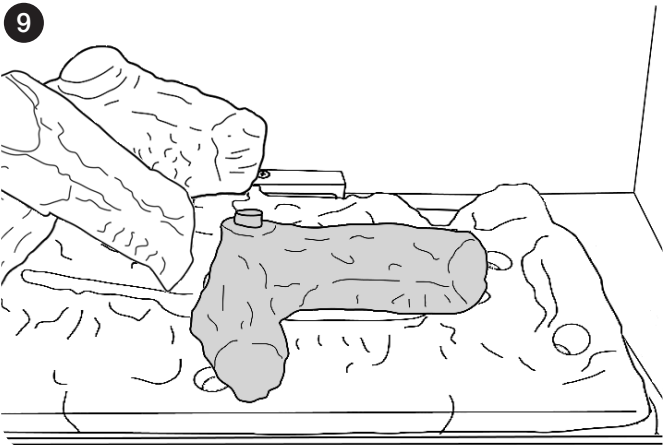
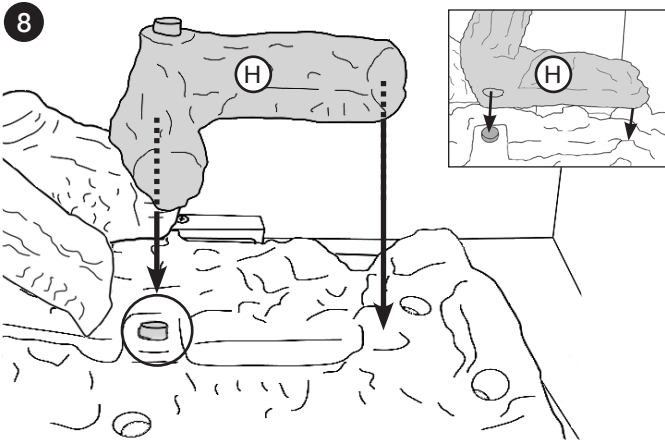
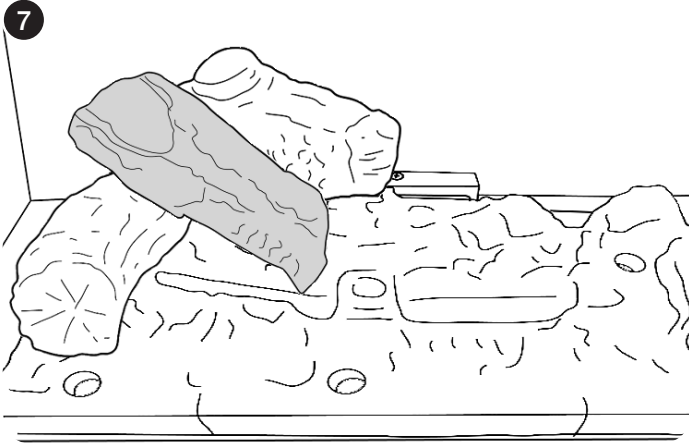

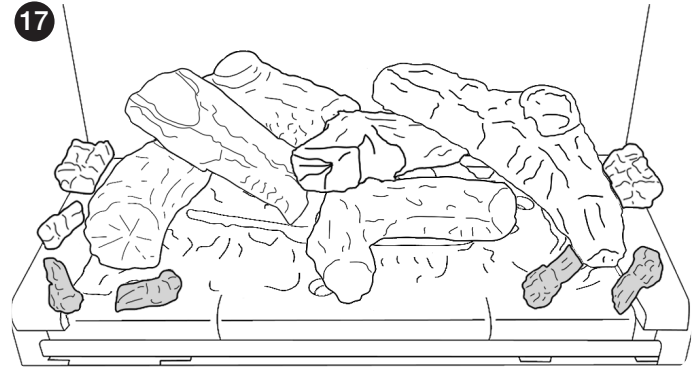
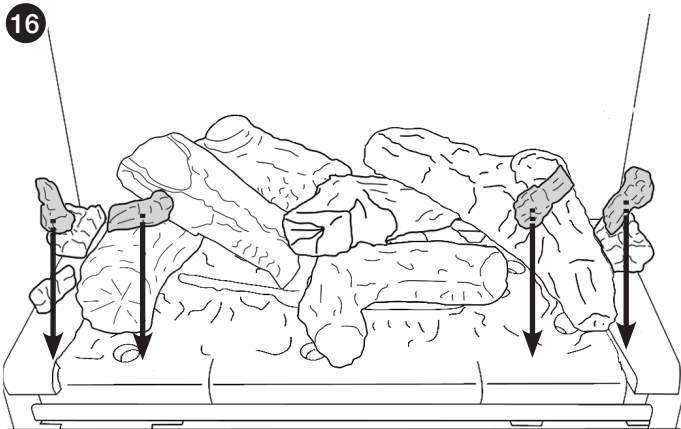

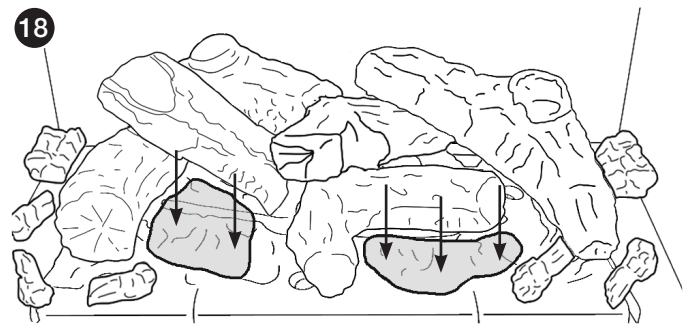

Sparingly lay Embaglow over the small ports in the base of the burner tray. This will create a glowing effect when the appliance is lit.

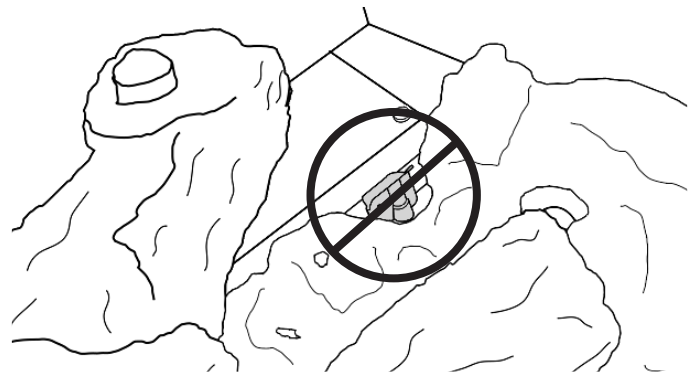

Take care not to use more than half a packet per application.
WARNING - DO NOT PLACE NEAR THE PILOT AREA.



 **NOTE: ENSURE THAT THE LOGS ARE POSITIONED AS ABOVE. ONLY USE THE CORRECT AMOUNT OF LOGS AS SPECIFIED IN THE DIAGRAMS.**

COMPLETION OF ASSEMBLY

Ensure that the rope seal on the back of the glass frame is intact.

To replace the glass frame, position so the hooks on the back of the frame fit over the side pins.



Push the handle down.

Replace the screws. As the screws are tightened the glass frame is pulled down against the hooks and forms a seal.

Replace ALL of the securing screws ensuring that a screw is present in all fixing slots.



UNDER NO CIRCUMSTANCES SHOULD THE APPLIANCE BE USED IF ANY OF THE GLASS FRAME RETAINING SCREWS ARE LOOSE OR MISSING.

Connect the battery lead to the battery pack attached to the lower slotted trim.



PLEASE ENSURE NO WIRES ARE TRAPPED BEFORE REPLACING THE LOWER SLOTTED TRIM. THE LEADS ARE EASILY DAMAGED.

Replace the lower trim, ensuring that the battery box is connected and in their correct orientation.

Replace the 2 magnetic side trims.

NEVER OPERATE THE APPLIANCE WHEN THE GLASS PANEL IS REMOVED OR BROKEN.

Replace the decorative front by referring to the separate leaflet supplied with the front.

NOTE: ENSURE THAT THE LOGS ARE POSITIONED AS ABOVE. ONLY USE THE CORRECT AMOUNT OF LOGS AS SPECIFIED IN THE DIAGRAMS.

LIGHTING THE APPLIANCE

The appliance is operated by thermostatic remote control.



This remote controls the appliance from pilot ignition through to shut down.

In 'MANUAL MODE' you can:

- light the pilot
- turn on the main burner
- regulate the flame from low to high and back
- turn off the burner leaving just the pilot burning

In 'TEMP MODE' you can:

- set the room temperature so the stove automatically maintains that temperature

In 'TIMER MODE' the appliance:

- turns on and off according to the set time periods
- automatically regulates the room temperature during the set periods

Turning the appliance On

Your remote can control the gas appliance from pilot ignition through to shut down.

To turn the appliance on press the OFF button and the UP button simultaneously. You hear several short signals.

The pilot and main burner ignite and the remote is now in Manual Mode:

Turning the appliance Off:

Press the OFF button to turn the appliance off.

FOR SAFETY, YOU MUST WAIT 30 SECONDS BEFORE LIGHTING THE APPLIANCE AGAIN.



IMPORTANT: YELLOW FLAMES TYPICALLY APPEAR WHEN THE APPLIANCE HAS REACHED NORMAL OPERATING TEMPERATURE. THIS CAN TAKE UP TO 30 MINUTES.



WARNING: IF THE APPLIANCE FAILS TO LIGHT OR BECOMES EXTINGUISHED IN USE, WAIT 3 MINUTES BEFORE ATTEMPTING TO RELIGHT.

FOR FULL OPERATING INSTRUCTIONS AND TROUBLESHOOTING SEE USER SECTION.

COMMISSIONING

Complete the Commissioning Checklist at the front of this manual covering:

- Thermocouple soundness checks.
This is to include ensuring the thermocouple is secure on the pilot bracket assembly, lead connection and integrity.
- Flue checks
- Gas checks
- Log layout - flame picture

For working pressure test, use the access panel at the gas connection ensuring the burner is in position. Refer to Installation Instructions.

Ensure all safety checks listed in the Commissioning Section are completed, paying particular attention to the glass panel checks and securing of the glass frame.

Upon completion of the commissioning and testing of the installation and correct operation of the appliance, the installer must instruct the user how to operate the appliance.

Guide the user through the User Instructions paying particular attention to:

Regular servicing (See User Instructions).

Ventilation (See User Instructions) - point out the ventilation positions where applicable.

Hot surfaces (See User Instructions).

How the appliance works with the remote control handset and the modes of operation (See User Instructions).

How to change settings in the auto mode and program modes of operation.

What to do if the appliance fails to operate (See User Instructions).

REPROGRAMMING HANDSET/ CONTROL BOX

To access the control box see Servicing Instructions Main Control Assembly.

- Press and hold the reset button on the control box until you hear two signals. After the second longer signal:
- Release the reset button and within 20 seconds:
- Press the DOWN button on the handset until you hear two additional short signals confirming the new code is set.

If there is a single long signal the code learning sequence has failed or the wiring is incorrect.

SERVICING/FAULT FINDING CHARTS

SERVICING REQUIREMENTS

IMPORTANT – The glass panels on this appliance should be checked for any signs of damage on the front face of the glass panel (scratches, scores, cracks or other surface defects). If damage is observed, the glass panel must be replaced and the appliance must not be used until a replacement is installed. Under no circumstances should the appliance be used if any damage is observed. Please isolate the appliance until a replacement glass panel has been obtained and installed. Replacement glass panels can be purchased from Gazco via the retailer from which the appliance was purchased or any other Gazco distributor.

This appliance must be serviced at least once a year by a competent person.

All tests must be carried out in accordance with the current Gas Safe recommendations.

Before Testing:

- Conduct a gas soundness test for the property ensuring there are no leaks before servicing.
- Check the operation of the appliance before testing.

Special checks:

- Clean the burners using a vacuum cleaner with a soft brush attachment. Ensure all debris is removed from the burner ports.
- Clean away lint or fluff from the pilot.
- Clean away lint or fluff from under the burner.
- Check the spark gap on the pilot is correct.
- Ensure that the glass is secured correctly and that all retaining screws are in place.

Correct any faults found during the initial test.

Re-commission the appliance in accordance with Commissioning Procedures of these instructions.

Advise the customer of any remedial work undertaken.

Electronic Control Valve Fault Analysis

SYMPTOM	CAUSE	REMEDY
Frequent beeps for 3 seconds after operation request	Batteries low in appliance	Replace appliance batteries
No ignition, 5 second continuous tone (there may be several short beeps before)	Loose/damaged wire	Check interrupter block and wires
No ignition, no tone, motor turns slightly when operated	Receiver board damaged	Replace receiver
No pilot flame and control continues to spark	Thermocouple circuit wired incorrectly	Correct wiring
Pilot lights, control continues to spark, value shuts down after 10 - 30 seconds	1. No spark at pilot burner 2. Loose/damaged wire	1. Rectify spark at pilot burner 2. Check interrupter and wires

FAULT FINDING CHARTS

IGNITION FUNCTIONAL CHECK 1

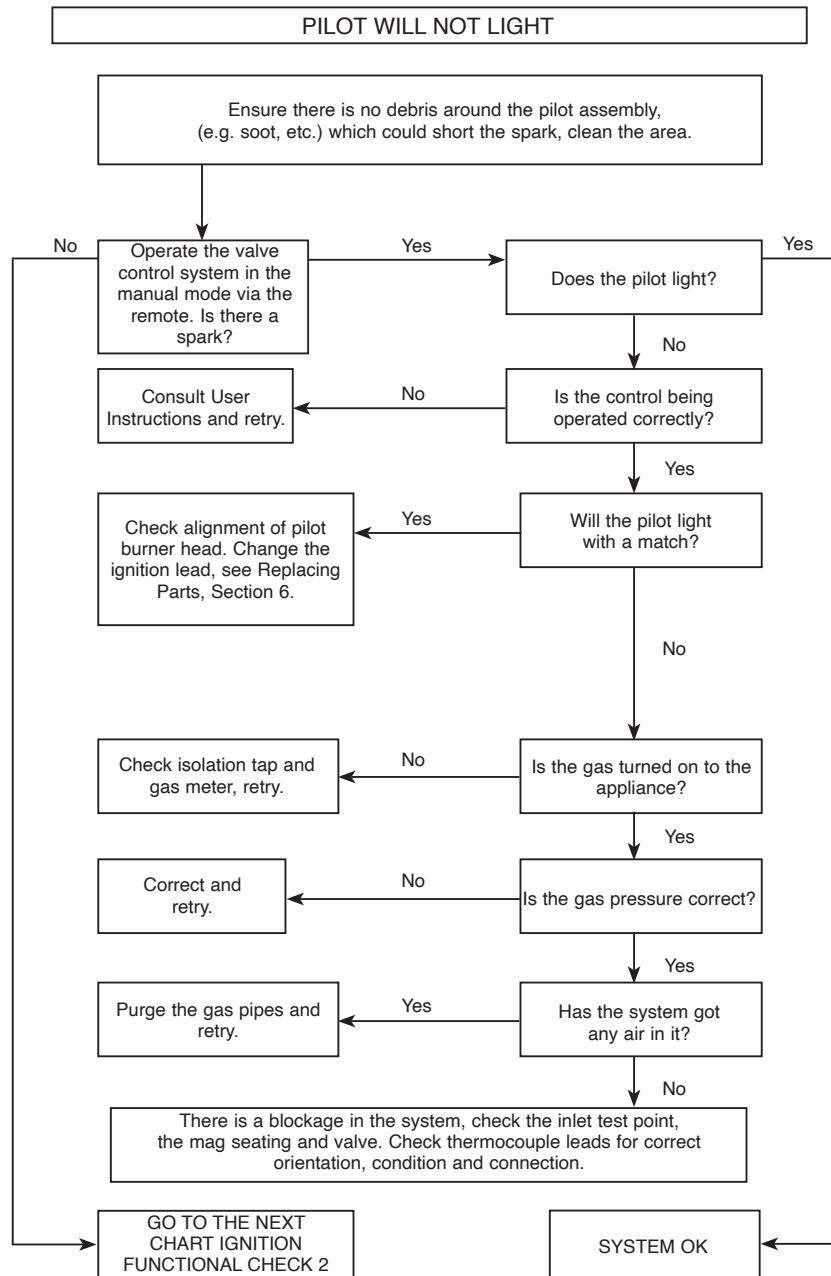

FAULT FINDING CHARTS

FLAME FAILURE FUNCTIONAL CHECK 3

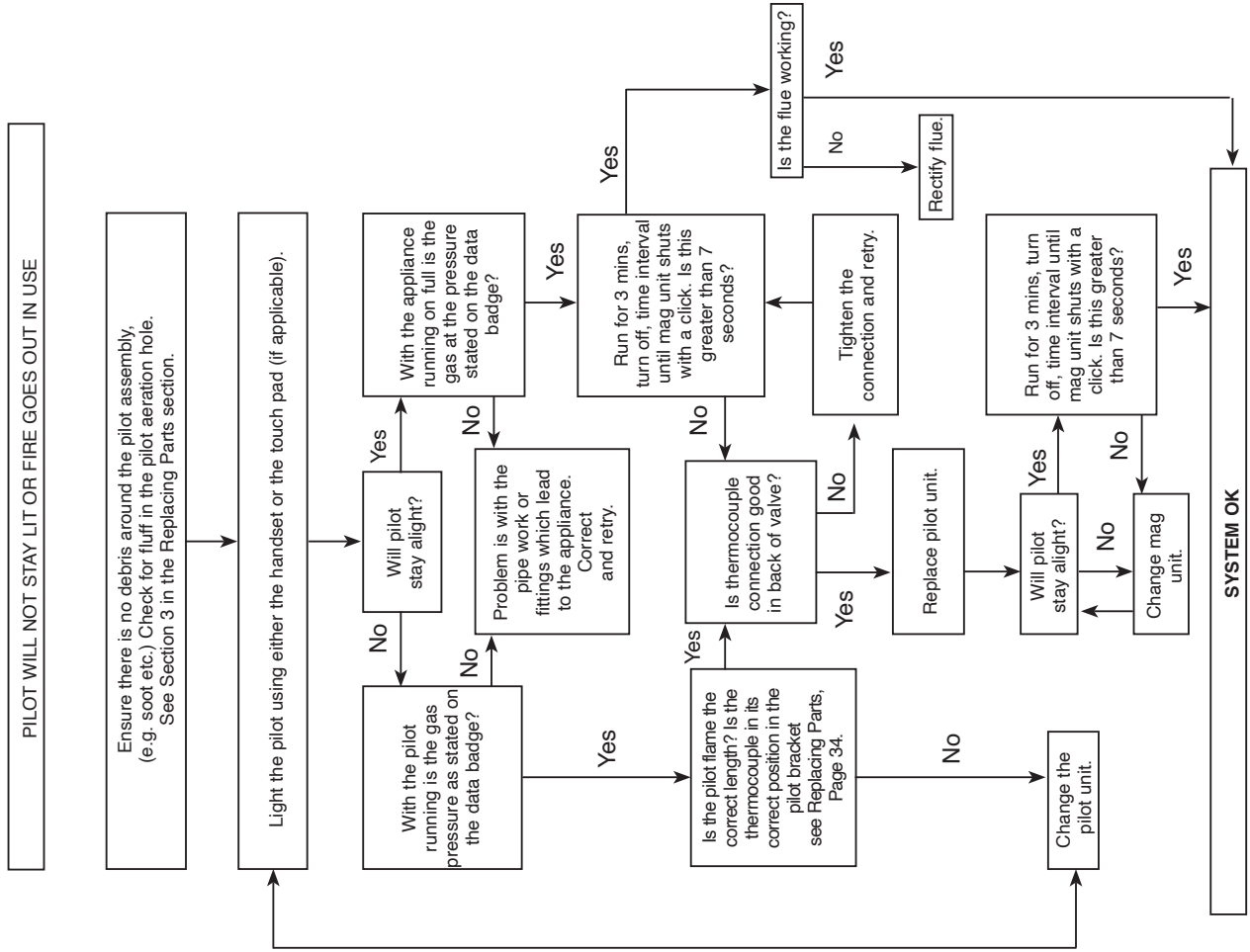

IGNITION FUNCTIONAL CHECK 2

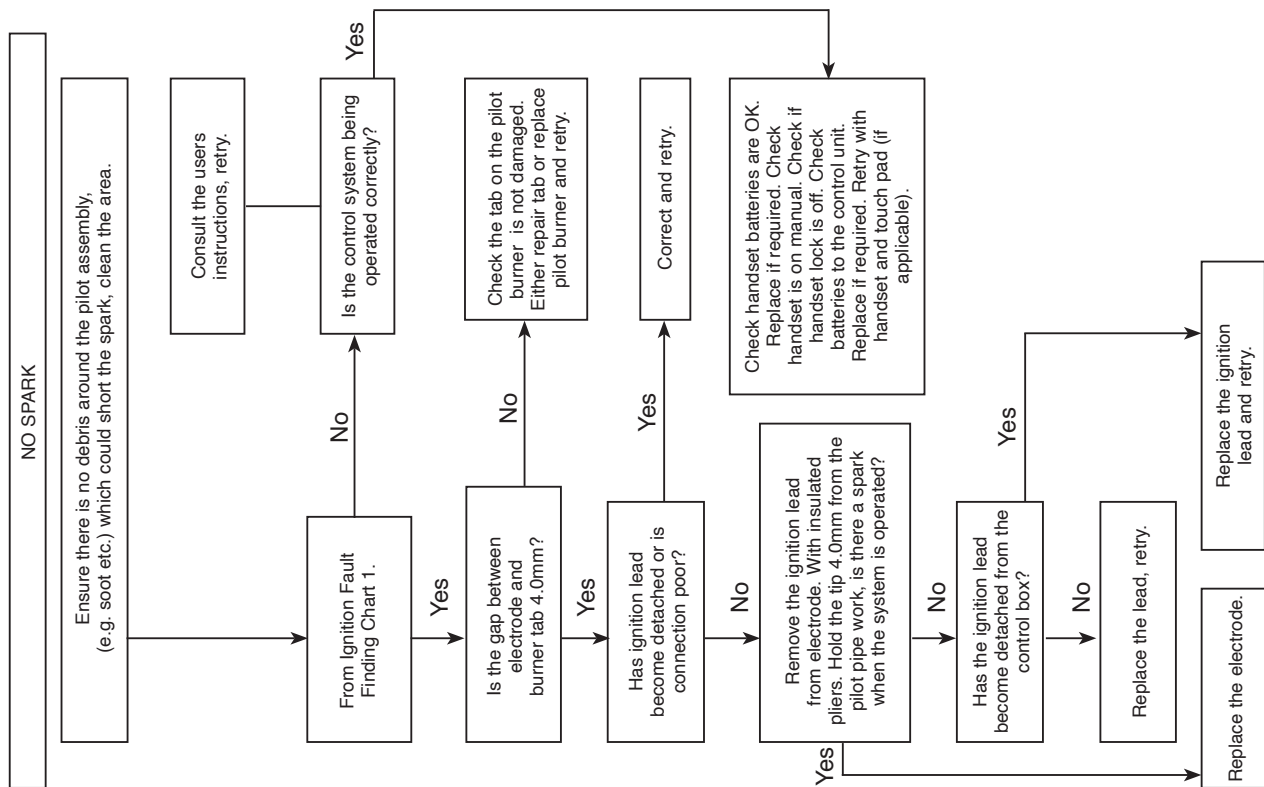

SERVICING

GENERAL

All main components can be replaced without removing the appliance from its installation.

IT IS ESSENTIAL THAT THE GAS SUPPLY TO THE APPLIANCE IS TURNED OFF AT THE ISOLATION DEVICE BEFORE PROCEEDING FURTHER.

It will be necessary to remove the burners and the fuel bed before any of the main components can be serviced.

! DURING SERVICING OF THIS APPLIANCE IT MAY BE NECESSARY TO CUT CABLE TIES IN ORDER TO ACCESS AND REMOVE SOME OF THE PARTS. THESE MUST BE REPLACED WHEN REASSEMBLING THE APPLIANCE.

REMOVING THE GLASS FRAME

Remove the glass door by removing the 2 side trims. These are held on by magnets.

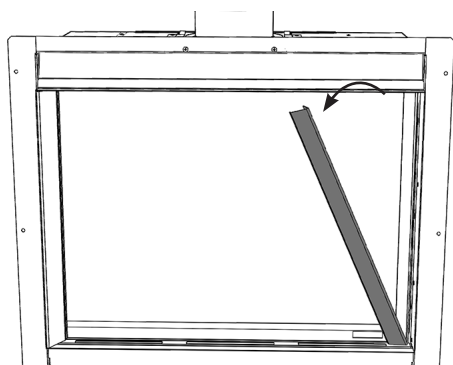

Lift out the bottom slotted trim. Note the orientation of the battery box for reassembly.

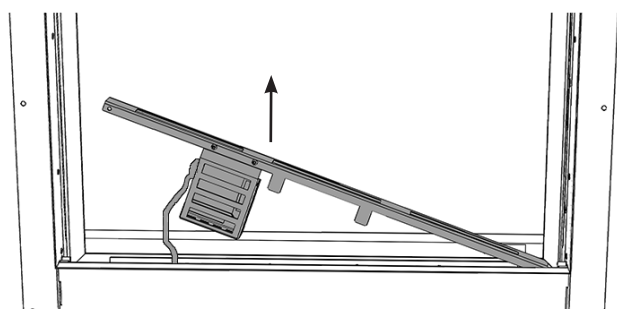

Disconnect the battery lead from the battery pack attached to the lower slotted trim.

Remove the screws at the base of the glass frame.

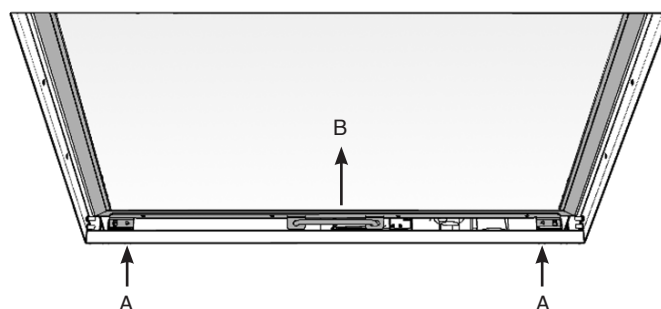

Pull up the handle at the front.

Whilst supporting the top, lift the glass frame using the handle, up and over the lower edge.

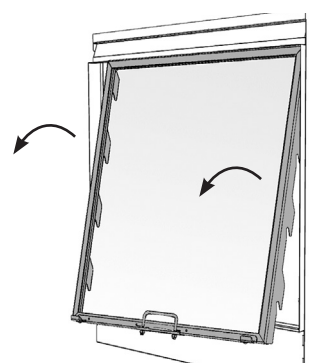

Remove the logs, and place them on a dry, clean surface.

When refitting the glass frame ensure that the fibreglass seal on the back of the frame is intact.

To replace the glass frame, position so the hooks on the back of the frame fit over the side pins.

Push the handle down.

Replace the screws. As the screws are tightened the glass frame is pulled down against the hooks and forms a seal.

Replace ALL of the securing screws ensuring that a screw is present in all fixing slots.

! UNDER NO CIRCUMSTANCES SHOULD THE APPLIANCE BE USED IF ANY OF THE GLASS FRAME RETAINING SCREWS ARE LOOSE OR MISSING.

Connect the battery lead to the battery pack attached to the lower slotted trim.

! PLEASE ENSURE NO WIRES ARE TRAPPED BEFORE REPLACING THE LOWER SLOTTED TRIM. THE LEADS ARE EASILY DAMAGED.

Replace the lower trim, ensuring that the battery box is connected and in the correct orientation.

Replace the 2 magnetic side trims.

NEVER OPERATE THE APPLIANCE WHEN THE GLASS PANEL IS REMOVED OR BROKEN.

The glass front must be refitted to the appliance following cleaning or servicing.

BAFFLE & VERMICULITE LINERS

Remove the 2 lower side cover panels, see Diagram.

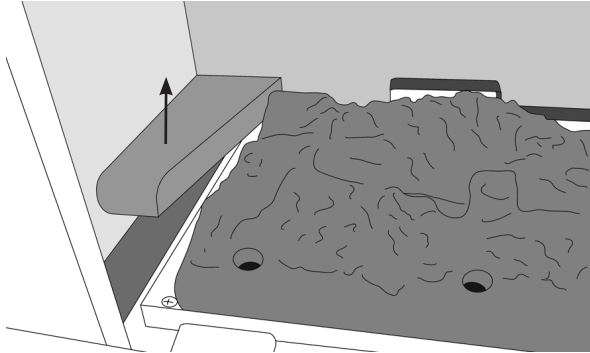

Remove the main burner.

Remove the rear log support brackets.

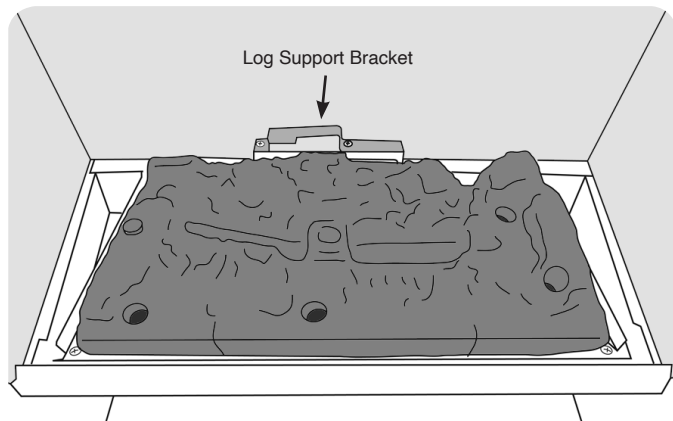

BAFFLE

The baffle must be removed before the liners can be taken out of the appliance.

The baffle is held in place by 5 screws, 3 at the front and 2 at the rear. The rear screws sit between slotted tabs, once the front screws are removed, loosen the rear screws and slide the baffle forward to remove.

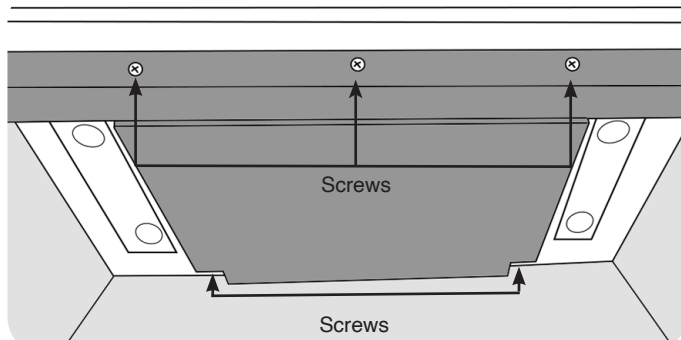

The baffle can now be removed by lowering the front edge and pulling forward through the front of the appliance.

TAKE CARE NOT TO DAMAGE THE SIDE PANELS

LINERS



BRICK EFFECT AND LEDGESTONE LINERS

These lining panel options are available for this product and contains Refractory Ceramic Fibre (RCF), a material which is commonly used for this application.

RCF waste is classed as stable, non-reactive hazardous waste and may be disposed of at a licensed landfill site.

If replacing these items do not break them up. Seal within heavy duty polythene bags and label as RCF waste.

Protective clothing is not required when handling these articles.

If the Liners are visibly broken Gazco recommend using gloves and a face mask to remove the pieces and remove any dust accumulated in and around the appliance before and after working on it with a HEPA filtered vacuum.

If any concerns remain contact Gazco Technical Customer Services to obtain the manufacturers COSHH Data Sheet.

Once the baffle has been placed carefully to one side the liners can then be taken out in the following order.

To remove the Right Hand liner first tilt inwards towards the centre of the firebox before lifting up and pulling out through the front of the firebox.

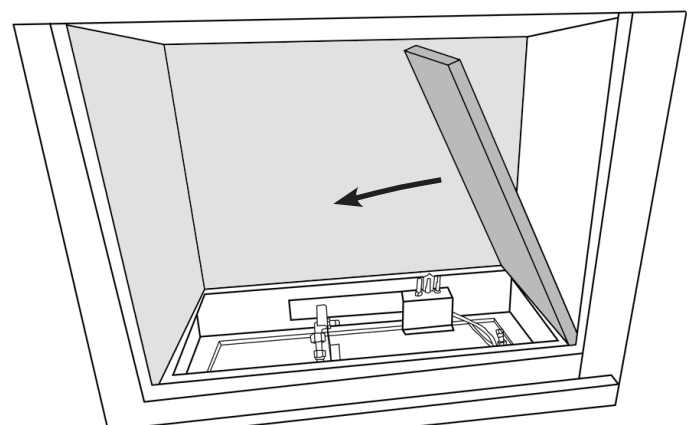

To remove the Left Hand liner first tilt inwards towards the centre of the firebox before lifting up and pulling out through the front of the firebox.

The 2 side liners also support the rear liner. Taking out the side liners will allow the rear liner to drop down so ensure it is supported.

Carefully remove the back liner by tilting the top forward and lifting over the pilot. Twist slightly to allow it to be removed through the front of the appliance.

Take care not to damage the pilot.

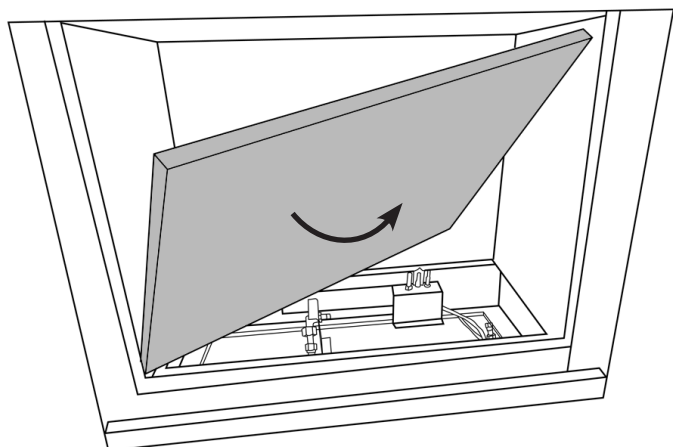

To replace the liners and baffle reverse these procedures.

MAIN BURNER

Remove the 2 lower side cover panels.

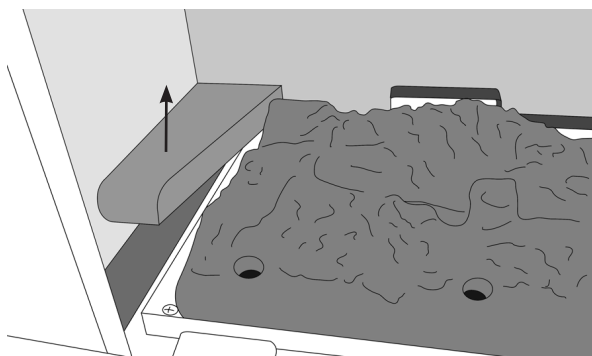

Remove the 2 screws at the front of the burner unit.

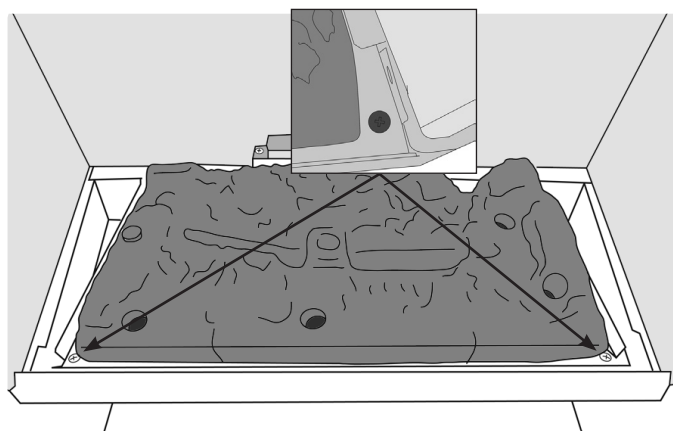

Slide the burner unit to the right, pull slightly forward and lift from the back. Carefully remove through the front of the appliance. Place carefully to one side.

Note: When reinstalling the burner unit ensure that the tabs at the back of the burner tray engage in the channel under the back panel.

MAIN CONTROL ASSEMBLY

Remove the glass frame.

Remove the main burner.

Remove the 4 screws to remove the access plate.

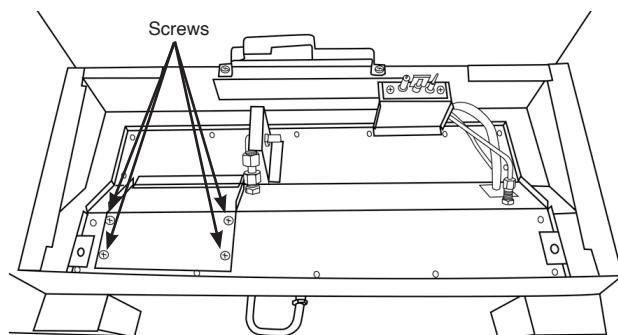

Turn the gas supply off at the isolation device.

HAVE YOU ISOLATED THE GAS SUPPLY?

Disconnect the isolating device from the appliance inlet pipe to isolate the gas supply.

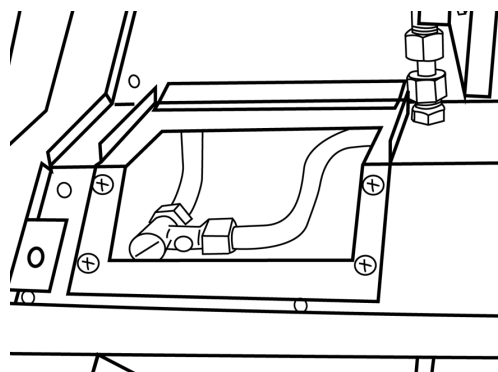

Remove the 15 screws securing the control assembly.

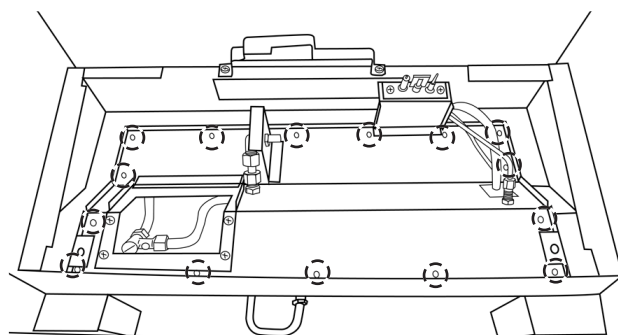

Lift the back of the control assembly and tilt forward to enable access to the controls.

Disconnect the battery supply cable from the control unit.

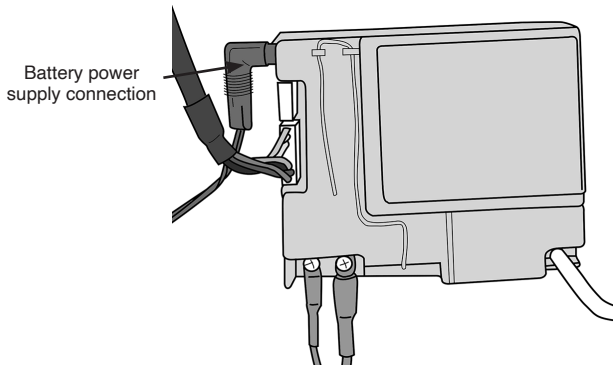

The control assembly can now be lifted and removed through the front of the appliance.

Replace in reverse order.

PILOT UNIT

The pilot assembly consists of four components, which can be individually changed, these are:

- Pilot burner bracket
- Electrode
- Pilot Injector
- Thermocouple

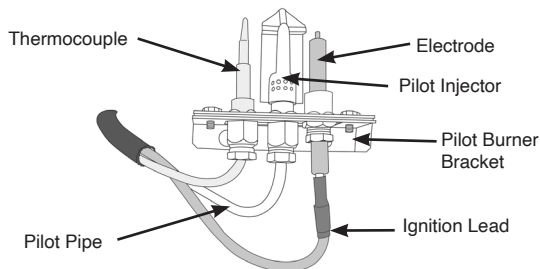

IMPORTANT: UNDER THE TERMS OF THE EXTENDED WARRANTY IT WILL BE COMPULSORY TO CHANGE THE COMPLETE PILOT UNIT ON THIS APPLIANCE IN YEARS 2 AND 4.

Turn off the gas supply at the isolating device.

Remove the main burner and the main control assembly.

PILOT BURNER BRACKET

To remove the Pilot Burner Bracket:

- Disconnect the Ignition lead.
- Loosen thermocouple nut.
- Undo the brass nuts connecting the pilot pipe to the brass fitting and the pilot unit and remove the pilot pipe.

IMPORTANT Ensure not to lose the loose injector component.

- Remove the 2 screws from the top of the bracket.

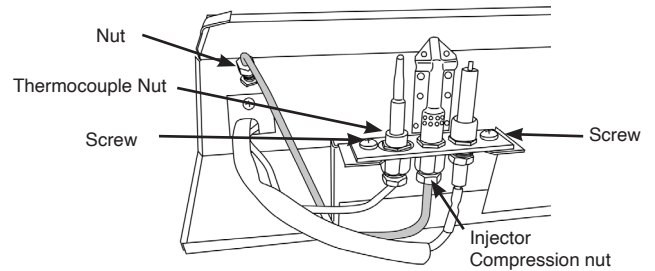

The pilot unit can now be removed and the pilot components can now be individually removed and replaced.

ELECTRODE

Pull the ignition lead off the electrode and undo the retaining nut.

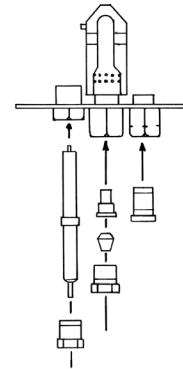

Replace with a new electrode.
Do not over-tighten the nut; this could break the component.

Replace the ignition lead.

PILOT INJECTOR

Undo the pilot pipe from the gas valve and from the underside of the pilot burner.

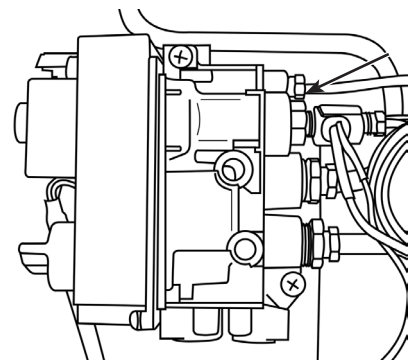

Remove the pipe and the injector drops out from the burner.

THERMOCOUPLE

IMPORTANT The Ignition lead and the Thermocouple need to be removed at the same time regardless of which needs to be replaced.

Unplug the Ignition lead from the electrode and undo the brass nut to remove the thermocouple from the pilot burner unit.

Undo the brass nut from the back of the interrupter block to disconnect the thermocouple.

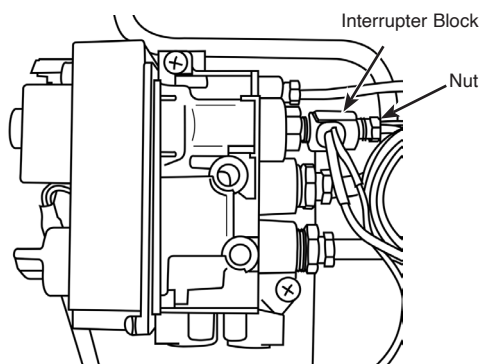

Unplug the Ignition lead from the control box.

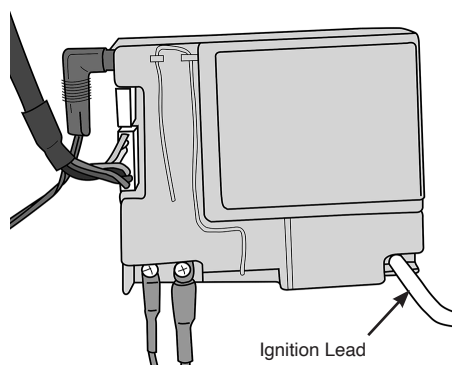

Carefully cut cable ties from the vidaflex.

IMPORTANT Ensure not to cut the cables.

Remove screw and sealant from plate.

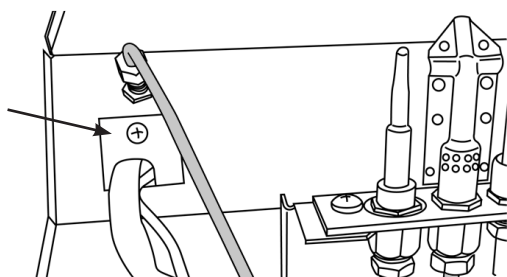

Feed ignition lead and thermocouple complete with vidaflex through metal plate.

Withdraw ignition lead and thermocouple from vidaflex sleeve. THIS MUST BE KEPT AND ASSEMBLED ON THE NEW LEAD. A CABLE TIE MUST ALSO BE USED TO RETAIN THE SLEEVE.

IMPORTANT The cables must follow the same route when they are replaced.

When replacing the cover plate ensure silicone sealant is used to seal the aperture.

The cable can only be fitted on way round, ensure this is correct when refitting a replacement.

IMPORTANT Ensure that the red end of the ignition cable is reconnected to the electrode.

IGNITION LEAD

IMPORTANT The Ignition lead and the Thermocouple need to be removed at the same time regardless of which needs to be replaced.

GAS VALVE

To change the gas valve:

Remove the main burner and the main control assembly.

Release the gas inlet pipe, see Arrow A.

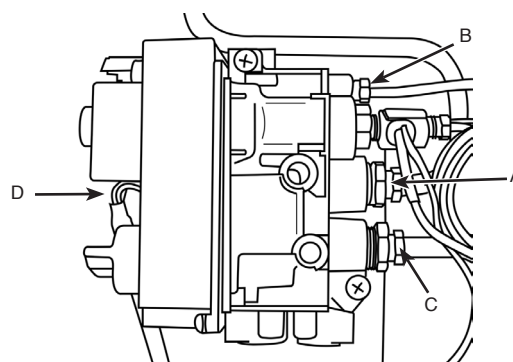

Remove the thermocouple from the interrupter block.

Release the pilot pipe, see Arrow B.

Release the gas outlet pipe, see Arrow C.

Remove the eight wire loom, see Arrow D.

Remove the two screws securing the valve to the support bracket and withdraw the valve.

Replace in reverse order.

MAGNETIC SAFETY VALVE

To replace the magnetic safety valve:

Undo the thermocouple from the interrupter block and remove the two interrupter leads.

Unscrew the interrupter block from the back of the valve.

Undo the silver magnetic valve retaining nut on the back of the valve.

Gently tap out the mag valve.

Replace with a new unit.

Reassemble in reverse order ensuring that the interrupter leads are connected correctly with the blue tag lead furthest away from the gas valve body.

CONTROL BOX

Remove the main burner and the main control assembly.

Remove the two thermocurrent cables by removing the two screws.

Remove the ignition lead.

Remove the eight wire loom from the control box.

Remove the battery extension cable.

The control box can now be replaced.

When replacing the sealing plate on the rear of the control cover use a suitable silicone sealant.

After replacing the control box you may need to reprogram the handset.

- Press and hold the reset button on the control box until you hear two signals. After the second longer signal:
- Release the reset button and within 20 seconds:
- Press the DOWN button on the handset until you hear two additional short signals confirming the new code is set.

If there is a single long signal the code learning sequence has failed or the wiring is incorrect.

MAIN INJECTOR

Remove the main burner.

Undo the 2 nuts and the lock nut.

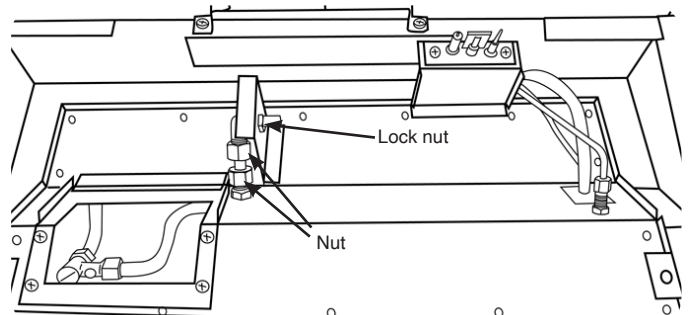

The injector can now be replaced.

Reassemble in reverse order.

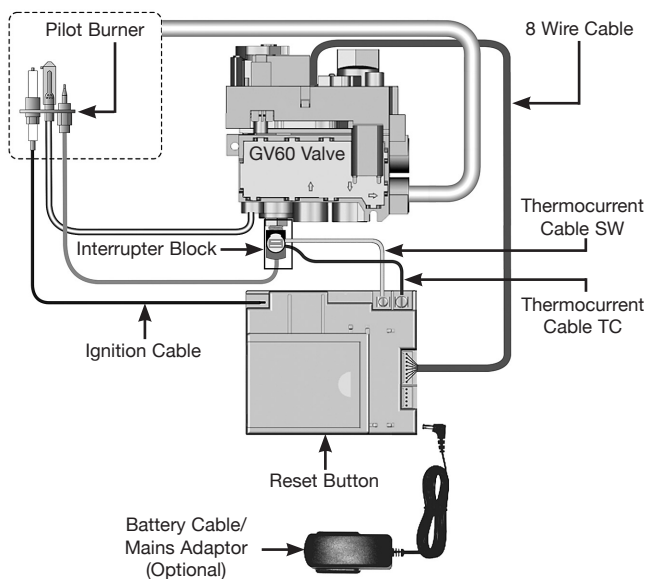

PRIMARY AERATION PLATE

Remove the burner unit.

Turn the burn unit over and place on a soft surface so as to not damage the unit.

Undo the 2 nuts to remove the plate.

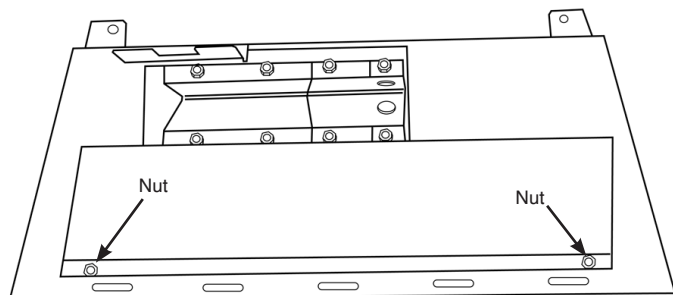

Remove the 2 fixing nuts and slide the plate off the venturi, the Aeration Plate can now be replaced.

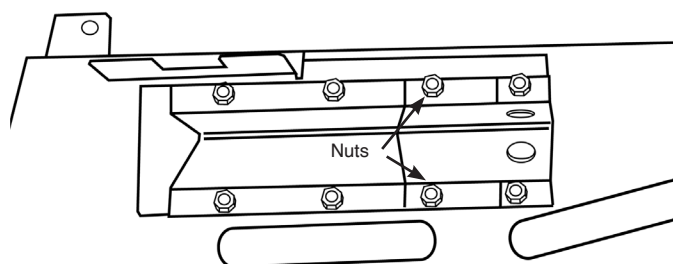

CHANGING BETWEEN GAS TYPES

In order to change between gas types it will be necessary to change both the burner assembly and the complete control assembly.

Contact your Gazco retailer for further information.

A kit of parts is available for this. Always quote the Model number and Serial number when ordering any spare parts.

PRODUCT MATERIAL INFORMATION

The following substances, preparations or components should be disposed of or recovered separately from other WEEE in compliance with Article 4 of EU Council Directive 75/442/EEC.

Metal	Steel	Can be taken to a local recycling centre for reuse to reduce waste going to landfill.
	Cast iron	
Glass		Can be taken to a local recycling centre for reuse to reduce waste going to landfill.
Vermiculite linings		Non hazardous material. Vermiculite can be crushed up and used for plant bedding and ash used for composting or disposed of at a local recycling centre for reuse to reduce waste going to landfill.
Rope seals/ Coal Fuel Effects/ Brick Effect, Ledgestone and Black Reed Liners		If the product contains any of the following: Rope seals, Coal Fuel Effects, Black Reed Brick Effect or Ledgestone Linings panels these items are made from Refractory Ceramic Fibre (RCF), a material which is commonly used for this application. Protective clothing is not required when handling these articles, but it is recommended to follow normal hygiene rules of not smoking, eating or drinking in the work area and always wash hands before eating or drinking. When servicing the appliance it is recommended that the replaced items are not broken up, but are sealed within heavy duty polythene bags and labelled as RCF waste. RCF waste is classed as stable, non-reactive hazardous waste and may be disposed of at a licensed landfill site.
Log Fuel Effects		Log Fuel effects are not considered hazardous to health, but are non-recyclable and must be disposed of in accordance to the rules in force.
Electrical components	(Fan kits etc if applicable)	Dispose of at a local recycling centre in accordance with the WEEE directive.

SPARES LIST - MAIN ASSEMBLY

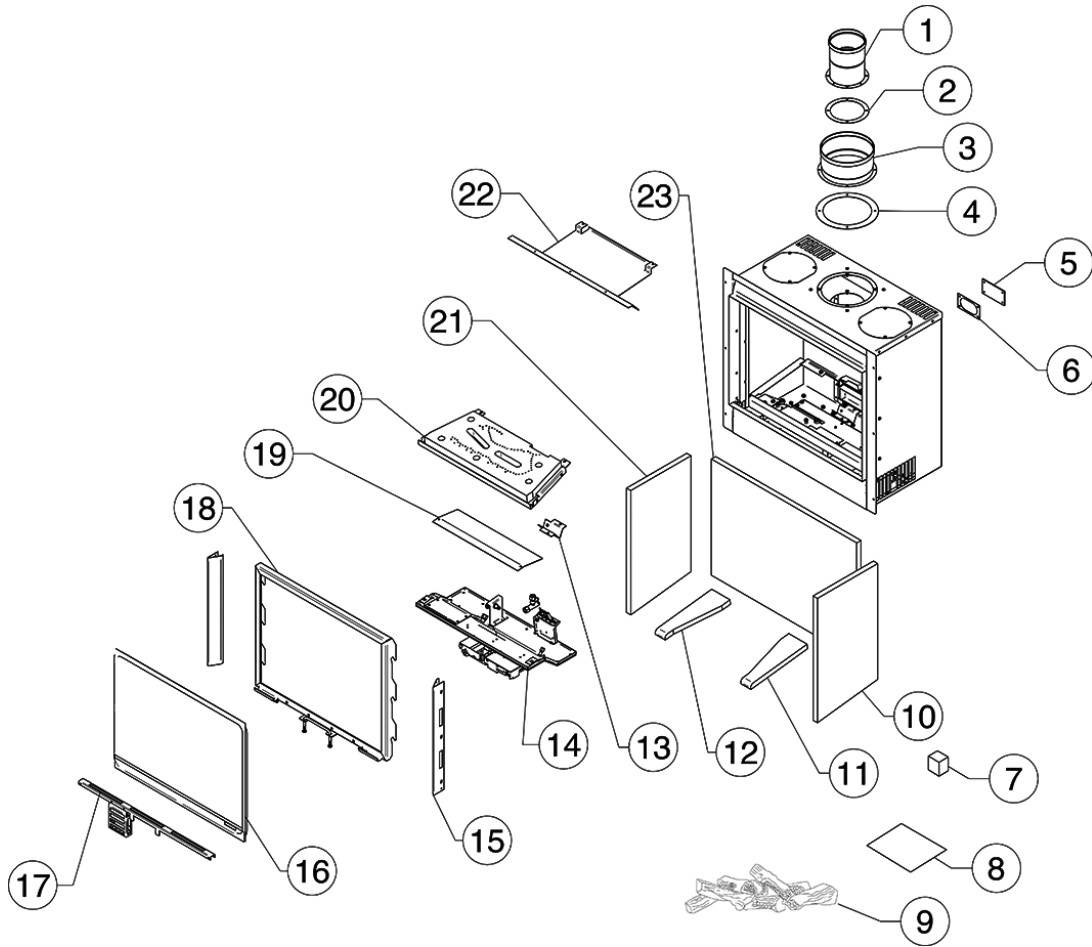

NO.	COMPONENT	PART CODE		QUANTITY
		NATURAL GAS	LPG	
1	Inner Spigot	MEC0231		1
2	Inner Flue Gasket	CE0210		1
3	Outer Spigot	MEC0232		1
4	Outer Flue Gasket	CE0211		1
5	Inlet Plate Silicone Seal	FA0354		1
6	Inlet Plate	ME3746		1
7	Embaglow	GZ8471		1
8	Instruction & Fixing Kit	GZ11921		1
9	Log Set	CE1058		1
10*	Vermiculite Lining RH	CE1321		1
	Black Reed Lining RH	CE1328		1
	Black Glass Lining RH	GZ12939		1
11	Vermiculite Only Lining Side Slip RH	CE1041		1
	Lining Side Slip RH	CE1068		1
12	Vermiculite Only Lining Side Slip LH	CE1041		1
	Lining Side Slip LH	CE1067		1

NO.	COMPONENT	PART CODE		QUANTITY
		NATURAL GAS	LPG	
13	Aeration Plate	GZ11271	GZ10412	1
14	Engine Assembly	GZ11873N	GZ11873P	1
15	Side Frame Cover	GZ9695		2
16	Glass & Ropeseal Assembly	GZ11033		1
17	Base Infill Trim	GZ16012		1
18	Door Assembly	GZ10986		1
19	Burner Baffle	GZ11039		1
20	Burner Assembly	GZ9963		1
21*	Vermiculite Lining LH	CE1320		1
	Black Reed Lining LH	CE1327		1
	Black Glass Lining LH	GZ12940		1
22	Top Baffle	GZ10797		1
23*	Vermiculite Lining Rear	CE1319		1
	Black Reed Lining Rear	CE1326		1
	Black Glass Lining Rear	GZ12941		1

* Ledgestone and Brick Effect Panels can only be purchased as a complete set due to colour matching issues:
 Ledgestone - 934-219
 Brick Effect - 934-203



Due to continual technical improvements please check online or with your Gazco retailer for the most up to date parts lists.

Only use Genuine Gazco spares when servicing your appliance. All of our essential spare parts and consumable items are available to purchase from our webshop at www.gazcospares.com.

SPARES LIST - CONTROL ASSEMBLY

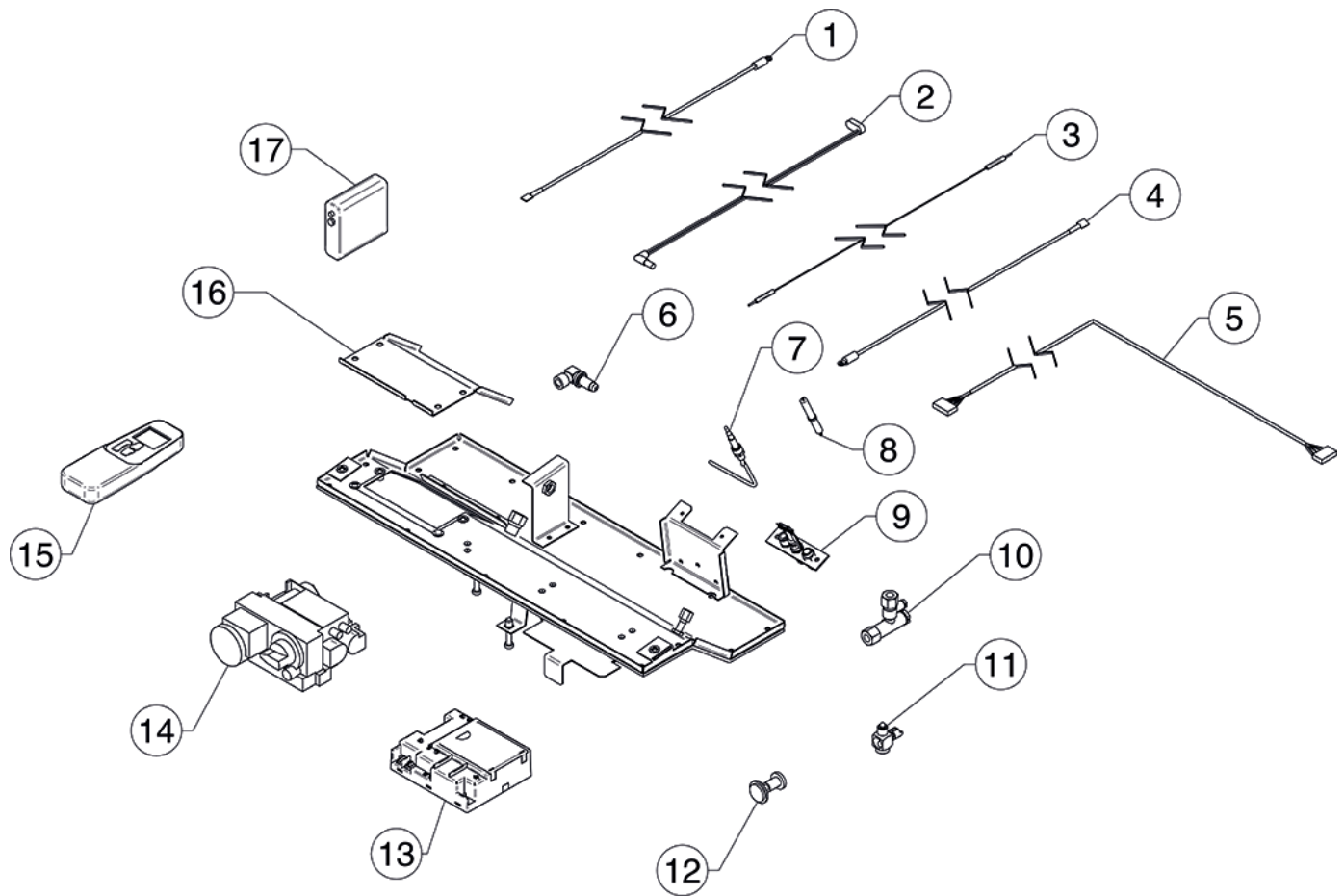

NO.	COMPONENT	PART CODE		QUANTITY
		NATURAL GAS	LPG	
1	Thermocurrent Cable	EL0590		1
2	0.5m Cable for Battery	GC0146		1
3	Ignition Cable	GC0125		1
4	Thermocurrent Cable	GC0126		1
5	Connection Cable	GC0133		1
6	Injector	IN0045	IN0055	1
7	Thermocouple	PI0074		1
8	Electrode	PI0075		1
9	Pilot Burner	PI0069	PI0070	1
10	Restrictor Elbow	GC0095		1

NO.	COMPONENT	PART CODE		QUANTITY
		NATURAL GAS	LPG	
11	Interruptor	GC0124		1
12	Mag Unit	GC0166		1
13	Receiver	EL0589		1
14	Control Unit	GC0123K		1
15	Thermostatic Handset	EL0571		1
16	Test Point Hatch	GZ11141		1
17	Battery Pack	EL0616		1



Due to continual technical improvements please check online or with your Gazco retailer for the most up to date parts lists.

Only use Genuine Gazco spares when servicing your appliance.

All of our essential spare parts and consumable items are available to purchase from our webshop at www.gazcospares.com.

SERVICE RECORDS

1ST SERVICE

Date of Service:.....

Next Service Due:.....

Signed:.....

Retailer's Stamp/GasSafe Registration Number

3RD SERVICE

Date of Service:.....

Next Service Due:.....

Signed:.....

Retailer's Stamp/GasSafe Registration Number

5TH SERVICE

Date of Service:.....

Next Service Due:.....

Signed:.....

Retailer's Stamp/GasSafe Registration Number

7TH SERVICE

Date of Service:.....

Next Service Due:.....

Signed:.....

Retailer's Stamp/GasSafe Registration Number

9TH SERVICE

Date of Service:.....

Next Service Due:.....

Signed:.....

Retailer's Stamp/GasSafe Registration Number

2ND SERVICE

Date of Service:.....

Next Service Due:.....

Signed:.....

Retailer's Stamp/GasSafe Registration Number

4TH SERVICE

Date of Service:.....

Next Service Due:.....

Signed:.....

Retailer's Stamp/GasSafe Registration Number

6TH SERVICE

Date of Service:.....

Next Service Due:.....

Signed:.....

Retailer's Stamp/GasSafe Registration Number

8TH SERVICE

Date of Service:.....

Next Service Due:.....

Signed:.....

Retailer's Stamp/GasSafe Registration Number

10TH SERVICE

Date of Service:.....

Next Service Due:.....

Signed:.....

Retailer's Stamp/GasSafe Registration Number

INFORMATION REQUIREMENT FOR GASEOUS FUEL LOCAL SPACE HEATER

Model	Riva2 500 BF NG	Riva2 500 BF LPG
Fuel	Space Heating Emissions (NOx) - mg / kWh _{input} (GCV)	130

Heat Output	Nominal Heat Output - P_{nom}	4.9kW	4.8kW
	Minimum Heat Output (indicative) - P_{min}	1.9kW	1.9kW

Auxiliary Electricity Consumption	At Nominal Heat Output - $e_{l,max}$	N/A	N/A
	At Minimum Heat Output - $e_{l,min}$	N/A	N/A
	In Standby Mode - $e_{l,sb}$	N/A	N/A

Useful Efficiency (NCV)	Useful Efficiency at nominal heat output - $\eta_{th,nom}$	93.9%	93.9%
	Useful Efficiency at minimum heat output (indicative) - $\eta_{th,min}$	72.0%	72.0%

Permanent Pilot Flame Power requirement	Permanent Pilot Flame Power requirement (if applicable) - P_{pilot}	N/A	N/A
--	---	-----	-----

Type of heat output/room temperature control

Electronic room temperature control + day timer	Yes	Yes
---	-----	-----

Other control options (multiple selections possible)

Room temperature control, with presence detection	No	No
Room temperature control, with open window detection	No	No
With distance control option	No	No
With adaptive start control	No	No
With working time limitation	No	No
With black bulb sensor	No	No

Energy Efficiency Index	89.9%	89.9%
Energy Efficiency Class	A	A

Contact:	Gazco Ltd, Osprey Road, Sowton Industrial Estate, Exeter, EX2 7JG
-----------------	---



Gazco Ltd, Osprey Road, Sowton Industrial Estate, Exeter, Devon, England EX2 7JG

Tel: (01392) 474011 Fax: (01392) 219932 E-mail: info@gazco.com www.gazco.com

E & O E



PR2413